

# User's Manual

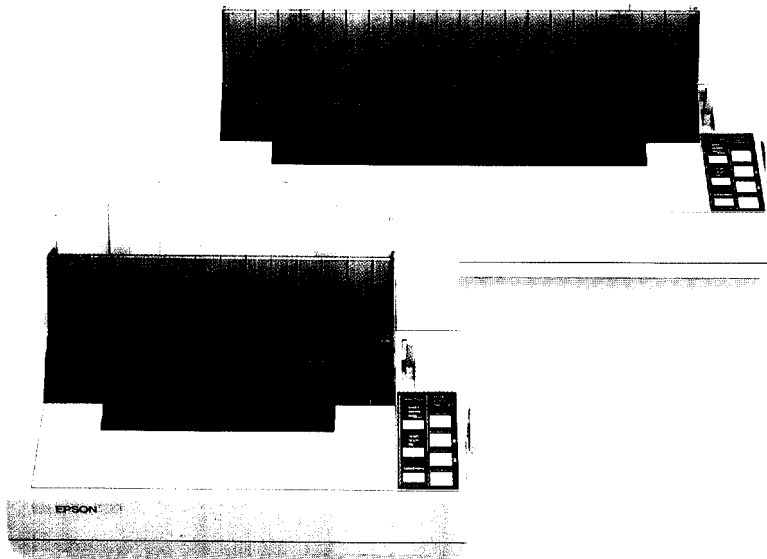

---

**EPSON®**

# EPSON® FX-850/1050

User's Manual

## FCC COMPLIANCE STATEMENT FOR AMERICAN USERS

This equipment generates and uses radio frequency energy and if not installed and used properly, that is, in strict accordance with the manufacturer's instructions, may cause interference to radio and television reception. It has been type tested and found to comply with the limits for a Class B computing device in accordance with the specifications in Subpart J of part 15 of FCC Rules, which are designed to provide reasonable protection against such interference in a residential installation. However, there is no guarantee that interference will not occur in a particular installation. If this equipment does cause interference to radio or television reception, which can be determined by turning the equipment off and on, the user is encouraged to try to correct the interference by one or more of the following measures:

- Reorient the receiving antenna
- Relocate the printer with respect to the receiver
- Plug the printer into a different outlet so that the printer and receiver are on different branch circuits.

If necessary, the user should consult the dealer or an experienced radio/television technician for additional suggestions. The user may find the following booklet prepared by the Federal Communications Commission helpful:

"Television Interference Handbook."

This booklet is available from the U.S. Government Printing Office, Washington, DC 20402. Stock No. 004-000-00450-7.

### WARNING

The connection of a nonshielded printer interface cable to this printer will invalidate the FCC Certification of this device and may cause interference levels which exceed the limits established by the FCC for this equipment. If this equipment has more than one interface connector, do not leave cables connected to unused interfaces.

All rights reserved. No part of this publication may be reproduced, stored in a retrieval system, or transmitted, in any form or by any means, mechanical, photocopying, recording or otherwise, without the prior written permission of Seiko Epson Corporation. No patent liability is assumed with respect to the use of the information contained herein. While every precaution has been taken in the preparation of this book, Seiko Epson Corporation assumes no responsibility for errors or omissions. Neither is any liability assumed for damages resulting from the use of the information contained herein.

Seiko Epson Corporation shall not be held liable for any damages or problems arising from the use of any options other than those designated as Original Epson Products by Seiko Epson Corporation.

Centronics is a registered trademark of Centronics Data Computer Corporation.

Epson is a registered trademark of Seiko Epson Corporation.

IBM is a registered trademark of International Business Machines Corporation.

Copyright © 1988 by Seiko Epson Corporation  
Nagano, Japan

---

# Table of Contents

	<b>Introduction</b> .....	1
	<b>Features</b> .....	1
	Options .....	2
	About This Guide .....	2
<b>1</b>	<b>Setting Up the Printer</b> .....	<b>1-1</b>
	Unpacking the Printer .....	1-2
	Choosing a Place for the Printer .....	1-5
	Assembling the Printer .....	1-6
	Testing the Printer .....	1-12
	Connecting the Printer to Your Computer .....	1-18
<b>2</b>	<b>Paper Handling</b> .....	<b>2-1</b>
	Using Single Sheets .....	2-2
	Using Continuous Paper .....	2-4
	Switching Between Continuous and Single Sheets .....	2-10
	Adjusting the Loading Position .....	2-14
	Using Micro-Adjustment .....	2-14
	Using Short Tear-Off .....	2-15
	Printing on Special Paper .....	2-17
<b>3</b>	<b>Using the Printer</b> .....	<b>3-1</b>
	Operating the Control Panel .....	3-2
	Setting the DIP Switches .....	3-5
	Selecting Typestyles .....	3-10
	Enhancing Your Printing .....	3-13
<b>4</b>	<b>Using Software and Graphics</b> .....	<b>4-1</b>
	Using the FX with Application Programs .....	4-2
	Computer-Printer Communication .....	4-5
	Dot Graphics .....	4-8
	User-Defined Characters .....	4-19

<b>5</b>	<b>Maintenance</b> .....	5-1
	Cleaning the Printer .....	5-2
	Replacing the Ribbon .....	5-3
	Transporting the Printer .....	5-6
<b>6</b>	<b>Troubleshooting</b> .....	6-1
	Problems and Solutions .....	6-2
	Data Dump Mode .....	6-5
<b>7</b>	<b>Using Printer Options</b> .....	7-1
	The Cut Sheet Feeder .....	7-2
	The Pull Tractor .....	7-15
	Interface Boards .....	7-22
<b>8</b>	<b>Command Summary</b> .....	8-1
	Commands in Numerical Order .....	8-4
	Epson (ESC/P) Commands .....	8-8
	IBM Emulation Mode Commands .....	8-41
	<b>Appendix A: Technical Specifications</b> .....	A-1
	Printer Specifications .....	A-2
	Interface Specifications .....	A-5
	Initialization .....	A-8
	<b>Appendix B: Tables</b> .....	B-1
	Proportional Width Table .....	B-2
	Character Tables .....	B-6
	<b>Glossary</b> .....	GL-1
	<b>Index</b> .....	Index-1

---

# Introduction

The FX-850 and FX-1050 printers combine all the well-known features of previous Epson® 9-pin printers with many features normally exclusive to costly 24-pin printers.

## Features

In addition to the high-quality printing and ease of operation you've come to expect from Epson printers, the FX-850 and FX-1050 offer the following:

- An advanced paper handling system that lets you use single sheets of paper without removing the continuous paper. This system allows you to use continuous paper even while the optional cut sheet feeder is attached.
- A new short tear-off feature that saves paper. After you tear off the last sheet printed on continuous paper, the printer reverses the paper so that you can use all of the next sheet.
- A micro-adjustment feature that allows you to feed the paper forward or backward to finely adjust the loading and short tear-off positions.
- An improved control panel design that allows direct selection of character fonts and pitch, as well as a choice of draft or near letter quality (NLQ) printing.
- Draft mode with fast printing of up to 264 characters per second at 12 cpi.
- The ability to handle a wide range of paper types, including envelopes.
- Double-high and double-wide printing for headings and special emphasis.

## **options**

A variety of printer options are available for use with FX printers. For detailed information on the installation and use of these options, see Chapter 7.

### **Single-bin cut sheet feeder**

The cut sheet feeder gives you easier and more efficient handling of single sheet paper. Up to 150 sheets of standard bond paper can be fed automatically into the printer without reloading. This unit also can automatically feed envelopes.

### **Pull tractor unit**

This option improves the performance of continuous paper handling. It is especially useful with continuous multi-part forms.

### **Optional interface boards**

A number of optional interfaces can be used to supplement the FX's built-in parallel interface. Guidelines for choosing the right interface and instructions on installing the boards are given in the section on interface boards in Chapter 7.

## **About This Guide**

This User's Guide provides fully illustrated, step-by-step instructions for setting up and operating the FX-850 and FX-1050 printers. The FX-850 and FX-1050 are basically the same printer except that the FX-1050 can accept wider paper. The illustrations in this manual usually show the FX-1050 printer.

### **Finding your way around**

Chapter 1 contains information on unpacking, setting up, testing, and connecting the printer. Be sure to read and follow the instructions in this chapter first.

Chapters 2 and 3 include important information on paper handling and general printer operation. This information is necessary for the day-to-day operation of your printer.

Chapter 4 contains information designed to help you get the most from your printer. This section includes advice on the use of software, printer commands, graphics, and user-defined characters. Also, see Chapter 8 for a summary of printer commands.

If the printer does not operate properly or the printed results are not what you expect, see Chapter 6 for a list of possible problems and recommended solutions.

Other chapters contain information on general maintenance, use of the printer options, and specifications. There is also a glossary of printer terms and an index.

At the back of this guide is a Quick Reference card that contains information about commands and settings for your printer.

## Conventions used in this guide



**WARNINGS:** must be followed carefully to avoid damage to your printer and computer.

**Cautions:** should be followed carefully to ensure that your printer operates correctly.

**Notes:** contain important information and useful tips on the operation of your printer.

# Setting Up the Printer

Unpacking the Printer .....	1-2
Removing the protective materials .....	1-3
Choosing a Place for the Printer .....	1-5
Assembling the Printer .....	1-6
Installing the platen knob .....	1-6
Installing the ribbon cartridge .....	1-8
Attaching the paper guide .....	1-11
Testing the Printer .....	1-12
Plugging in the printer .....	1-13
Loading a sheet of paper .....	1-13
Running the self test .....	1-16
Connecting the Printer to Your Computer .....	1-18
Connecting the parallel interface cable .....	1-18

## Unpacking the Printer

As you unpack the printer, check that you have all the parts shown below and **that** none has been damaged during transportation.

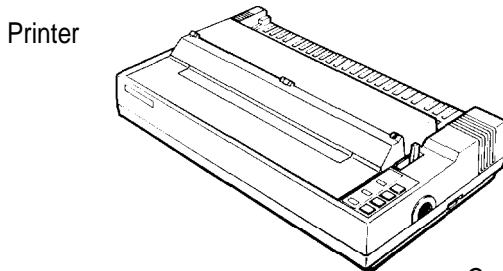

Cross-head screwdriver

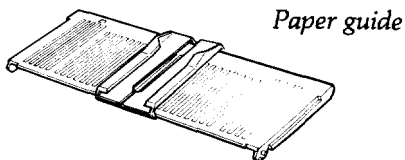

Platen knob

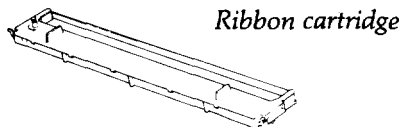

Note: You'll find the platen knob in a piece of the foam packing.

After removing **the** parts, store **the** packaging materials in case you ever need to transport your printer.

## Removing the protective materials

The printer is protected during shipping by two locking tabs and a print head protector. These protective items must be removed before you turn on the printer. After removing these items, store them with the other packaging material.

- 1 Remove the printer cover.

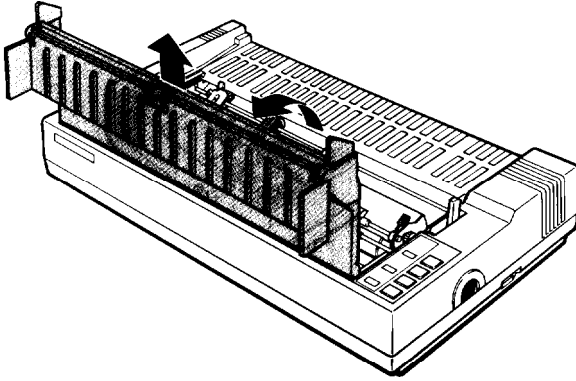

2. Remove the print head protector.

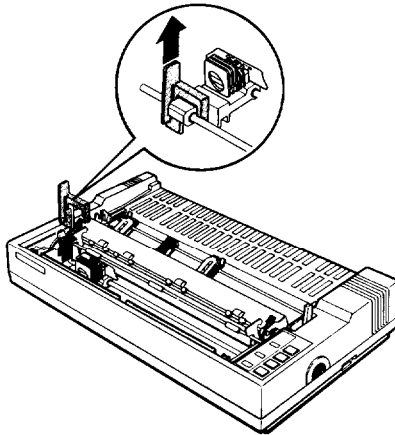

3. Remove the left and right locking tabs.

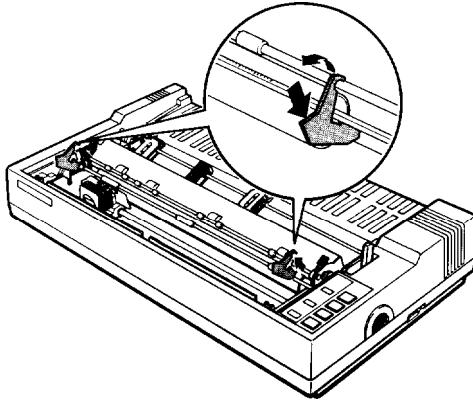

4. Slide the print head to the middle of the printer. Then, use the enclosed cross-head screwdriver to unscrew and remove the two transport locking brackets.

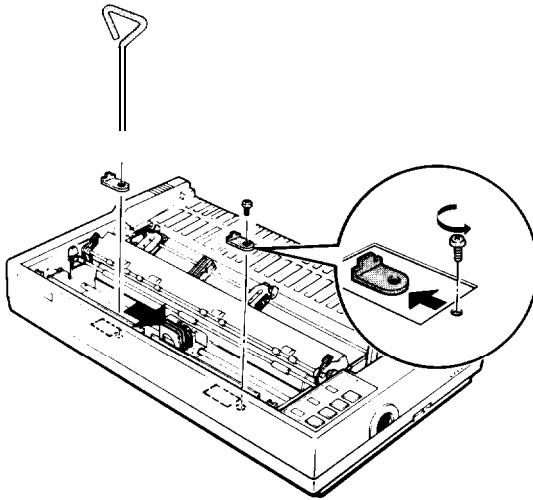

**WARNING:** Be sure to remove all protective materials before you turn on the printer.

## Choosing a Place for the Printer

When you select a location for your printer, keep the following in mind:

- Place the printer on a flat, stable surface.
- Place the printer close enough to the computer for its cable to reach.
- Leave adequate room around the printer to allow for easy operation and maintenance.
- Use a grounded outlet; do not use an adapter plug.

The illustration below shows a good printer setup.

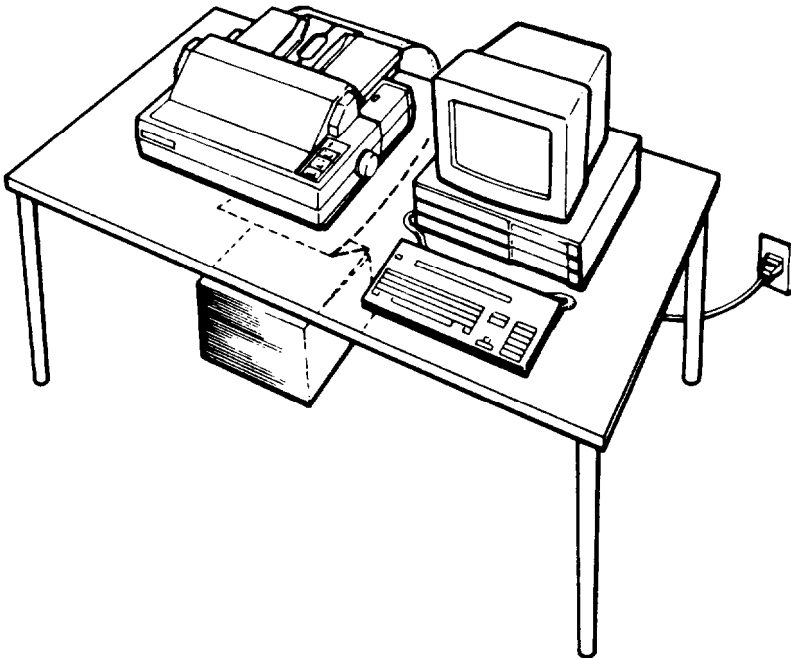



## W A R N I N G :

- Avoid locations that are subject to direct sunlight, excessive heat, moisture, or dust.
- Avoid using electrical outlets that are controlled by wall switches or automatic timers. Accidental disruption of power can wipe out information in both your computer's memory and your printer's memory.
- Avoid using outlets on the same circuit with large motors or other appliances that might disturb the power supply.
- Keep the entire computer system away from potential sources of interference such as loudspeakers or the base units of cordless telephones.

## Assembling the Printer

To assemble the printer, you need only do the following:

- Install the platen knob
- Install the ribbon cartridge
- Attach the paper guide.

### Installing the platen knob

The first step in setting up the printer is to install the platen knob. You should never need to use this knob during the normal operation of your printer. However, in case of a paper jam, you can use this knob to manually feed paper. (Be sure the printer is turned off before using the platen knob.)

You'll find the platen knob packed in an indentation in the white foam packing material.



1. Insert the knob into the hole on the printer's side and rotate it until it slips onto the shaft.

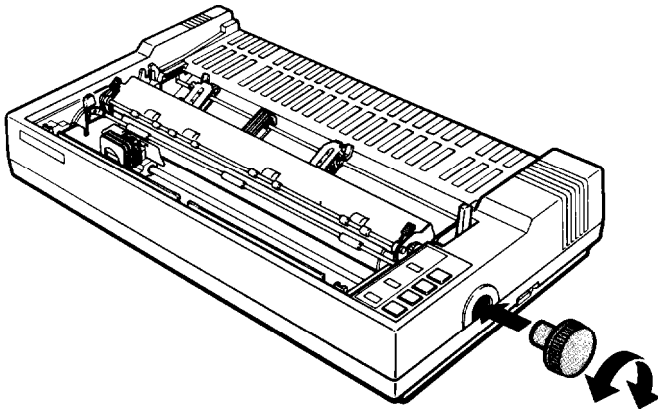

2. Push firmly on the knob until it fits against the printer case.

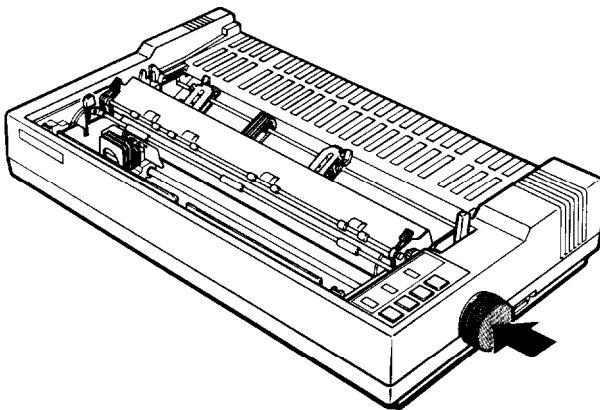

**Caution:** Never use the platen knob to adjust the position of the paper except in the case of a paper jam. Only use the platen knob when the printer is turned off.

## Installing the ribbon cartridge

Follow these steps to install the ribbon cartridge:

1. Slide the print head to the middle of the printer.

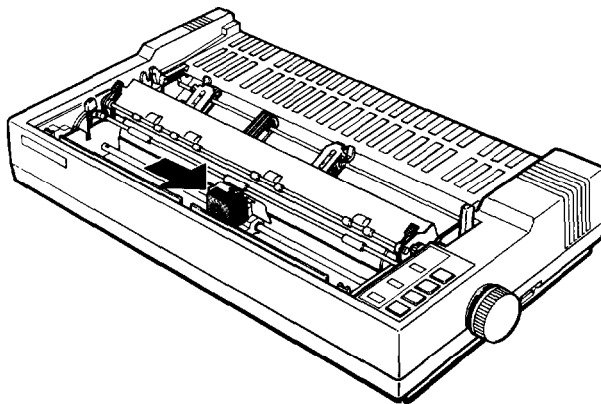

**Caution:** Never move the print head while the printer is turned on because this can damage the printer. Also, if you have been using the printer, the print head may be hot; let it cool for a few minutes before touching it.

2. Remove the ribbon cartridge from its box and remove the plastic wrapper.

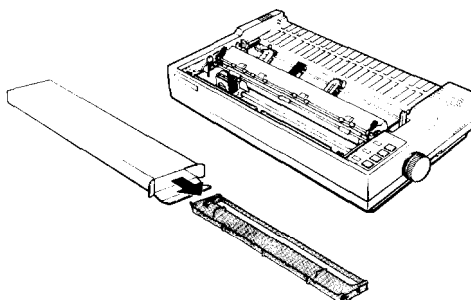

3. Turn the ribbon-tightening knob in the direction of the arrow. This removes any excess slack in the ribbon and makes it easier to install.

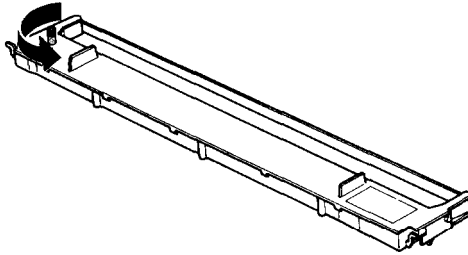

4. Hold the ribbon cartridge by its handles and push it firmly down into position, making sure the plastic hooks fit into the printer. (The FX-850 has only one handle in the center of the ribbon cartridge.)

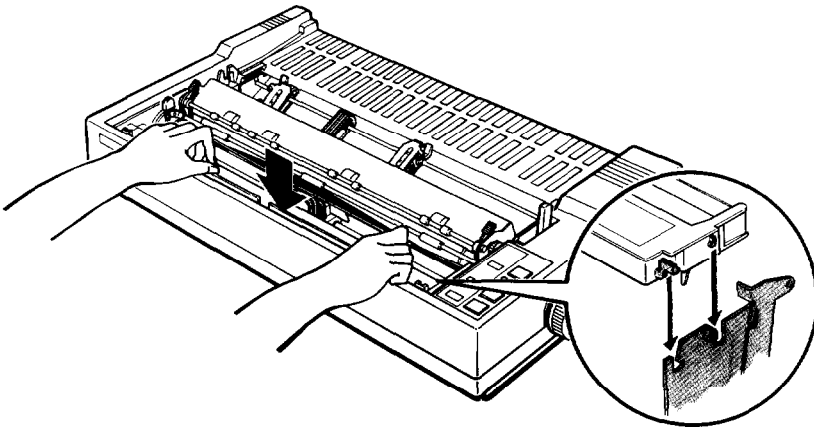

Press lightly on both sides of the cartridge to be sure the hooks are properly inserted.

5. Use a pointed object, such as the tip of a pencil, to guide the ribbon between the print head and ribbon guide while you turn the ribbon-tightening knob to help feed the ribbon into place.

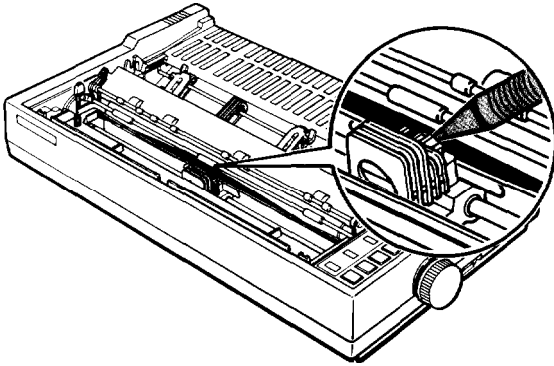

6. Slide the print head from side to side to make sure it moves smoothly. Also make sure the ribbon is not twisted or creased.

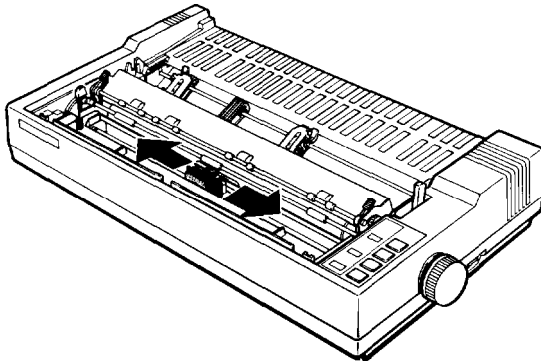

## Attaching the paper guide

The paper guide functions to feed the paper smoothly and efficiently. Follow these steps to install the paper guide:

1. Place the paper guide on the printer.

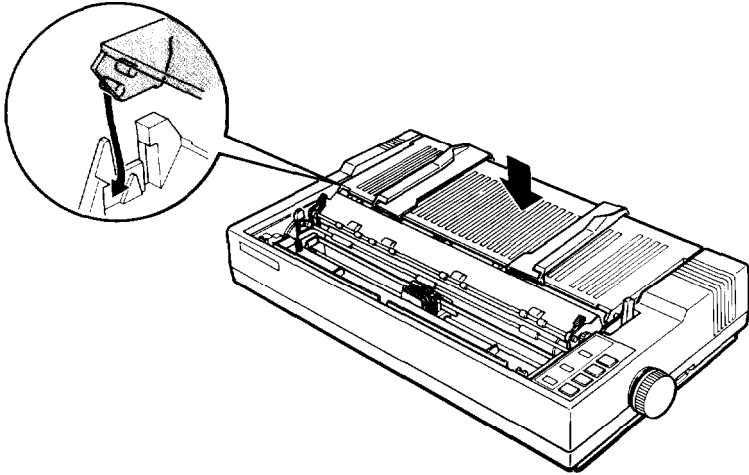

2. Raise the paper guide until it locks into place.

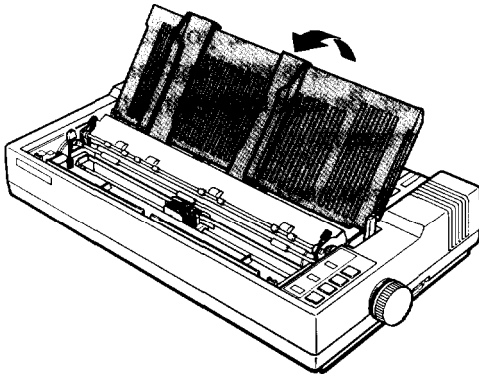

3. Now reinstall the printer cover by fitting the legs of the cover into the notches at the front of the printer.

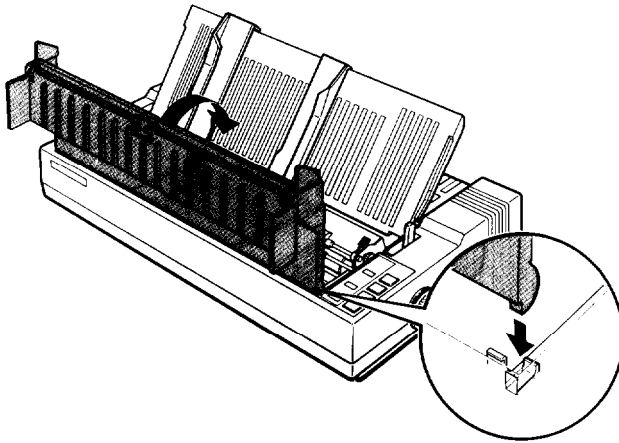

4. Close the printer cover.

## Testing the Printer

Now that your printer is fully assembled, you can use the built-in self test function to see that the printer is working correctly even though it is not connected to a computer. Be sure to perform this test to check that your printer is operating properly

Before running the self test, you need to connect your printer to an electrical outlet and load a sheet of paper.

## Plugging in the printer

Follow these steps to plug in the printer:

1. Be sure the printer is turned off.
2. Plug the power cable into a properly grounded electrical outlet.



**WARNING:** Whenever you turn off the power, wait at least five seconds before turning it back on. Rapid switching on and off can damage the printer.

## Loading a sheet of paper

Next, you need to load a sheet of paper that is letter size (if you have an FX-850) or 14 inches wide (if you have an FX-1050).



**WARNING:** Before turning on the printer, be absolutely sure you have removed all protective materials. Turning on the printer while the print head cannot move may seriously damage the print mechanism.

1. Turn on the printer. The green POWER and red PAPER OUT lights come on.

2. be sure that the paper release lever is pushed back to the single sheet position.

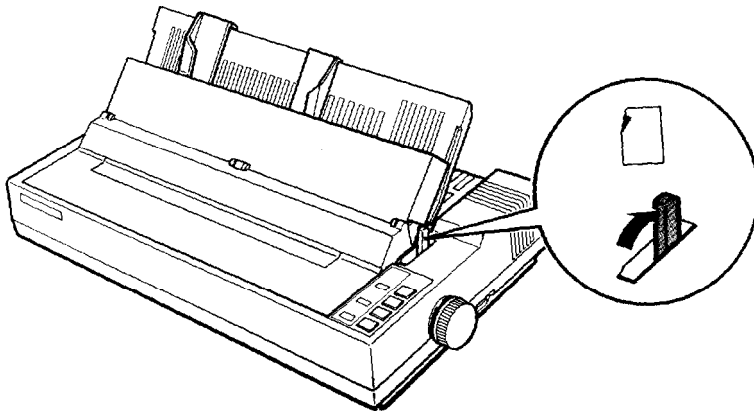

3. Move the left edge guide so it locks in place **next to the arrow** on the paper guide.

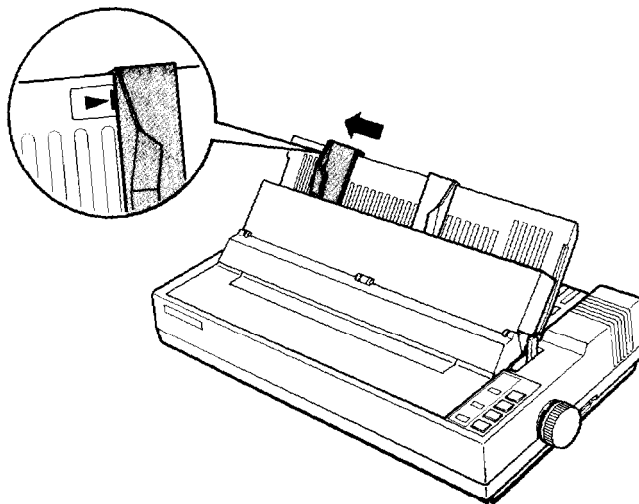

- Adjust the right edge guide to match the width of your paper. Next, slide a sheet down between the edge guides until it meets resistance.

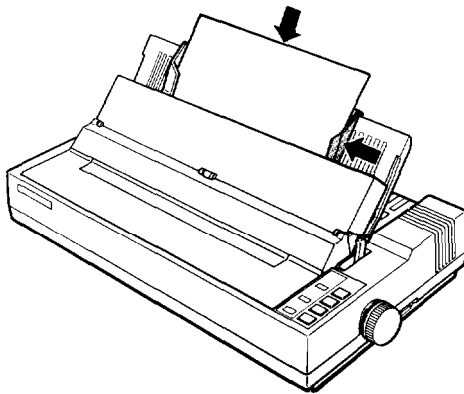

- Press the **LOAD/EJECT** button once to automatically load the paper. If the platen turns without loading the paper, remove the paper completely and re-insert it more firmly; then press the **LOAD/EJECT** button again.

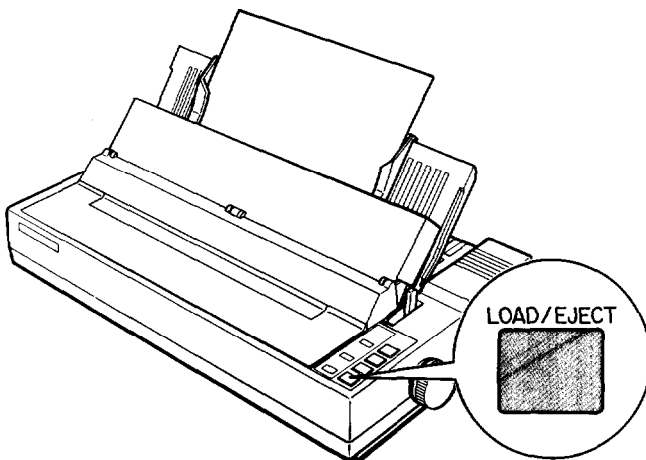

## Running the self test

The self test can be run in draft mode or near letter quality (NLQ) mode. Follow the steps below.

1. Load a sheet of paper as described above.



**WARNING:** Never run the self test using paper that is narrower than 8¼ inches if you have an FX-850, or 14 inches if you have an FX-1050, because you may seriously damage the print head.

2. Turn off the printer.
3. While holding down the **LINE FEED** button, turn on the printer. After printing starts, release the **LINE FEED** button.

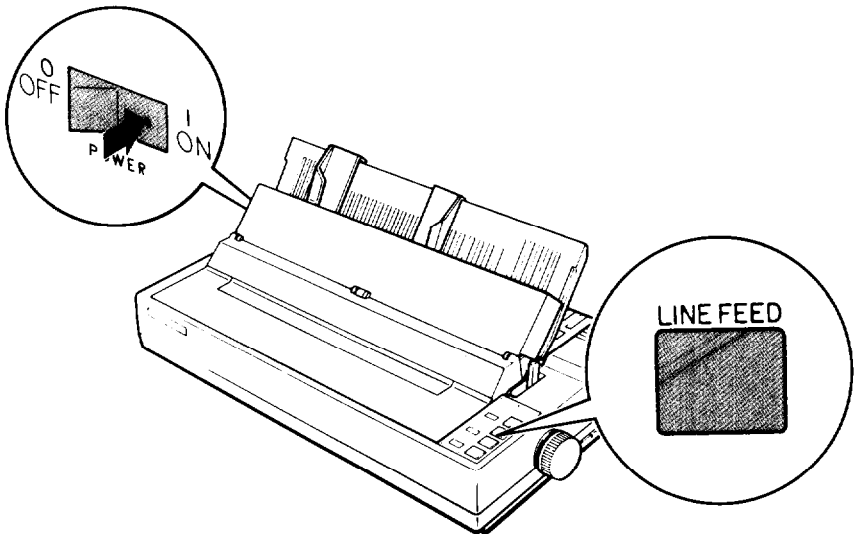

A list of your printer's settings is printed first, followed by a series of characters. Here is part of a typical draft self test:

Character mode	Normal	1-1 OFF
Shape of zero	0 (Unslashed)	1-2 OFF
CG Table	Graphics	1-3 ON
Print mode	ESC/P	1-4 OFF
Country	U.S.A.	1-5
\$%&'()*+,-./0123456789:;=<=>?@ABCDEFGHIJKLMN \$%&'()*+,-./0123456789:;=<=>?@ABCDEFGHIJKLMNO %&'()*+,-./0123456789:;=<=>?@ABCDEFGHIJKLMNO &'()*+,-./0123456789:;=<=>?@ABCDEFGHIJKLMNO '()*+,-./0123456789:;=<=>?@ABCDEFGHIJKLMNO ()*+,-./0123456789:;=<=>?@ABCDEFGHIJKLMNO		

- The self test continues until the paper runs out or until you press the **ON LINE** button. To stop the test temporarily, press the **ON LINE** button to take the printer off line.
- To end the self test, be sure **the printer is off line**. Press the **LOAD/EJECT** button to eject any paper that is still loaded, and then turn off the printer.

Note: When the cut sheet feeder is installed, the self test printout is **slightly** different. For details, see the section on the cut sheet feeder in Chapter 7.

To run the self test in NLQ mode, follow these steps:

- Load another **sheet** of paper as described above.
- Turn off the printer, then turn it on again while holding down the **FORM FEED** button. After printing starts, release the **FORM FEED** button.



2. Plug the cable connector securely into the printer.

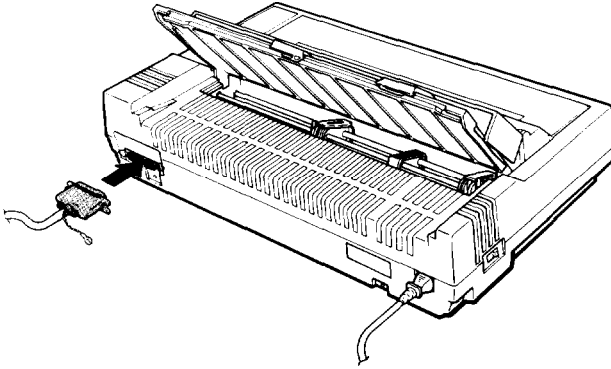

3. Squeeze the wire clips together until they lock in place on either side of the connector.

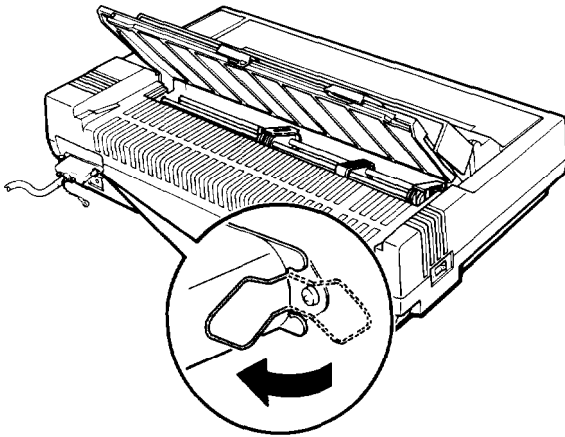

Note: For your printer to work properly, this connection must be secure.

4. If your cable has a ground wire, connect it to the ground connector beneath the interface connector.

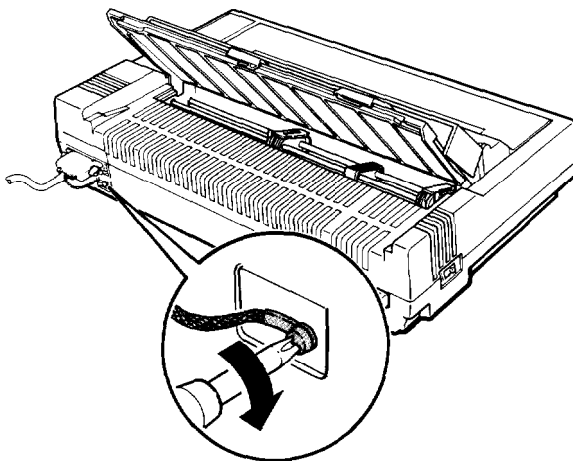

5. Plug the other end of the cable into the computer. (If there is a ground wire at the computer end of the cable, attach it to the ground connector at the back of the computer.)

# Paper Handling

Using Single Sheets .....	2-2
Reloading during printing .....	2-4
Using Continuous Paper .....	2-4
Positioning your continuous paper supply .....	2-9
Switching Between Continuous and Single Sheets .....	2-10
Switching back to continuous paper .....	2-13
Adjusting the Loading Position .....	2-14
Using Micro-Adjustment .....	2-14
Using Short Tear-Off .....	2-15
Printing on Special Paper .....	2-17
The paper thickness lever .....	2-17
Multi-part forms .....	2-18
Labels .....	2-19
Envelopes .....	2-19

## Using Single Sheets

Your printer can handle a wide range of paper sizes up to a maximum width of 10.1 inches on the FX-850 or 14.4 inches on the FX-1050.

Always make sure that your printing is confined to the size of paper you are using. Never print on the platen (black roller).

If you do most of your printing on single sheets, you may find it more convenient to install the optional cut sheet feeder. This option automatically inserts a new sheet whenever required and can hold up to 150 pages or 25 envelopes. For more details, see Chapter 7.

To load a single sheet of paper follow these steps:

Note: If you **already have** continuous paper loaded, follow the **instructions on page 2-10 for switching between continuous paper and single sheets.**

1. Turn on the printer.
2. Push the paper release lever back to the single sheet position.

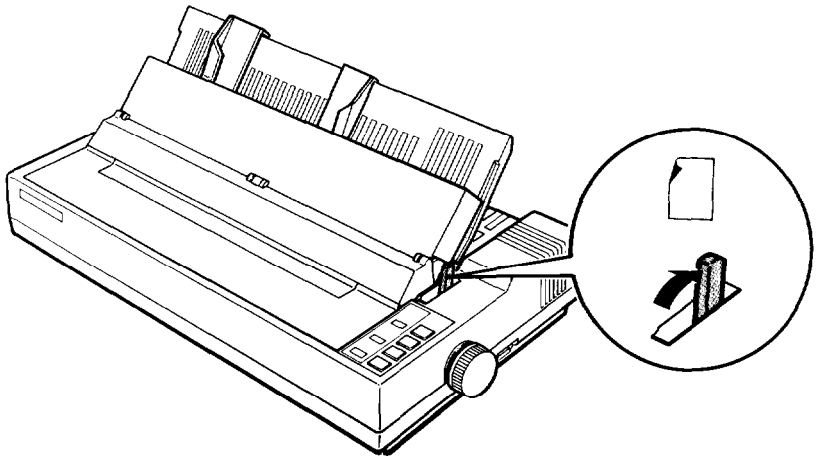

3. Stand the paper guide in an upright position and align the left edge guide with the arrow on the paper guide. (You may want to change this position later, depending **on** the margin settings of your application program.)

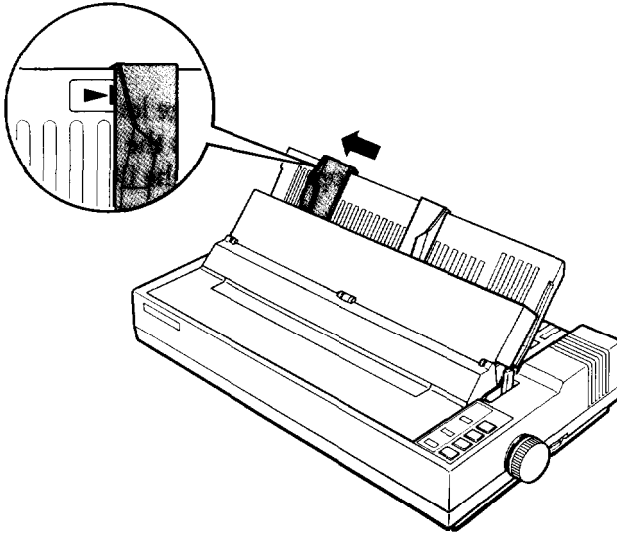

4. Adjust the **right** edge guide to fit the size of the paper.
5. Slide the paper down between the edge guides until it meets resistance. At this point, the **PAPER OUT** light turns off.
6. Press the **LOAD/EJECT** button to automatically feed the paper to the loading position.



**WARNING:** Never advance the paper using the platen knob while the printer is turned on.

7. Press the **ON LINE** button so that the **ON LINE** indicator lights up.

If the platen (black roller) turns but the sheet does not load, remove the sheet completely from the printer. Then make sure the paper release lever is pushed back. Press the paper a bit more firmly into place and try again.

To eject the paper, press the **ON LINE** button to take the printer off line, and press the **LOAD/EJECT** button.

## Reloading during printing

When you print a document more than one page long using single **sheet** paper, the printer stops printing when it reaches the bottom of the paper and ejects the page. When this happens, either the **ON LINE** light goes off automatically or it may remain on, depending on your application software. If the **ON LINE** light remains on, the first thing you should do is press the **ON LINE** button to take the printer off line. Once the **ON LINE** light is off, remove the sheet that has just been printed and load a new sheet as before. Press **ON LINE** to start printing the next page.

## Using Continuous Paper

The tractor built into the FX is remarkably easy to load and operate. Its low-profile design takes up little space and can handle a wide variety of paper widths.

To load continuous paper, follow these steps:

1. Turn off the printer.
2. Pull the paper release lever forward to the continuous paper position.

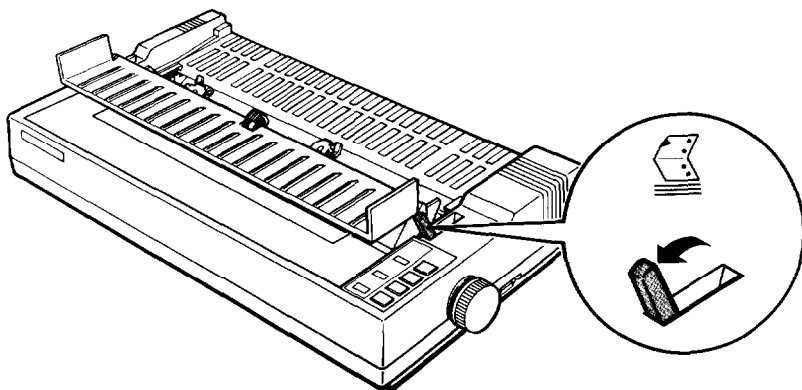

3. Release the sprocket lock levers by pulling each lever forward.

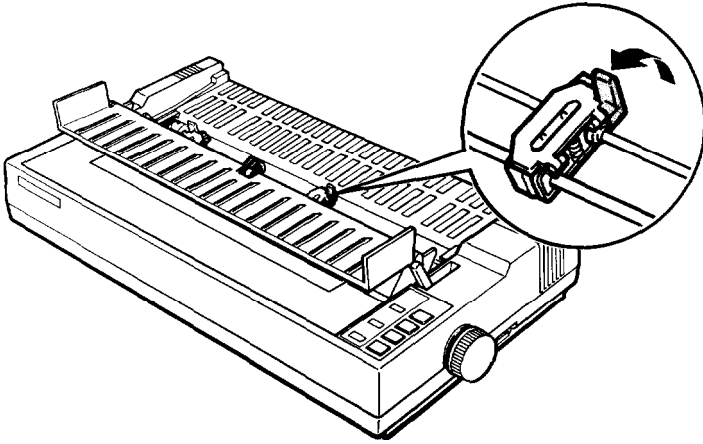

4. Slide the left sprocket unit all the way to the left and lock it in place.

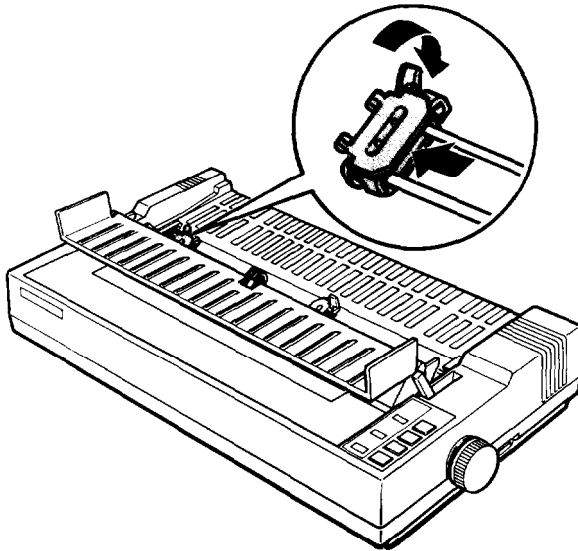

- Next, slide the right sprocket unit to match roughly the width of your paper. (Do not lock it.)
- Slide the paper support to a point midway between the sprocket units.

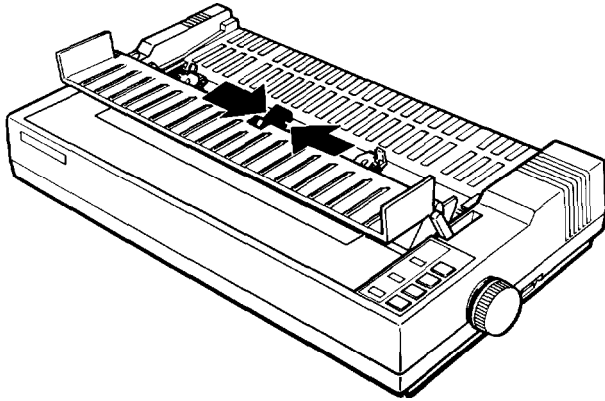

- Open both sprocket covers.

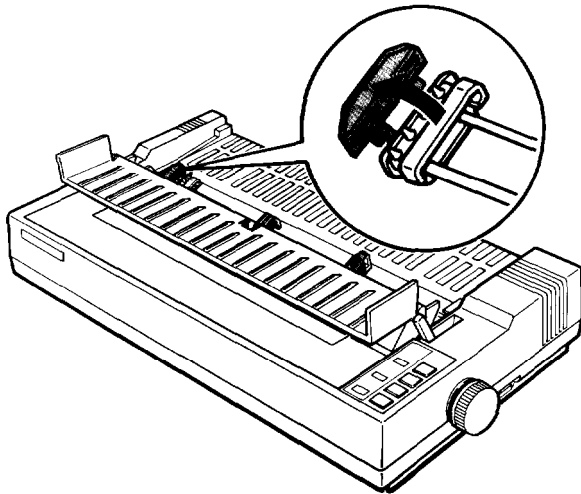

8. Fit the first four *holes* in the paper over the pins of the sprocket units as shown below. Then close the sprocket covers.

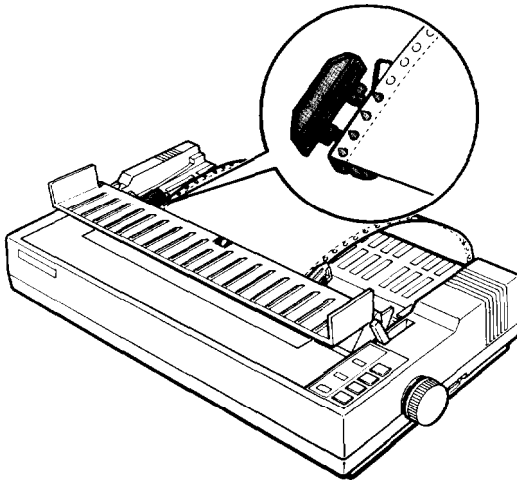

9. Slide the right sprocket unit to a position where the paper is straight and has no wrinkles, and then lock it in place.

10. Reattach the paper guide as shown below.

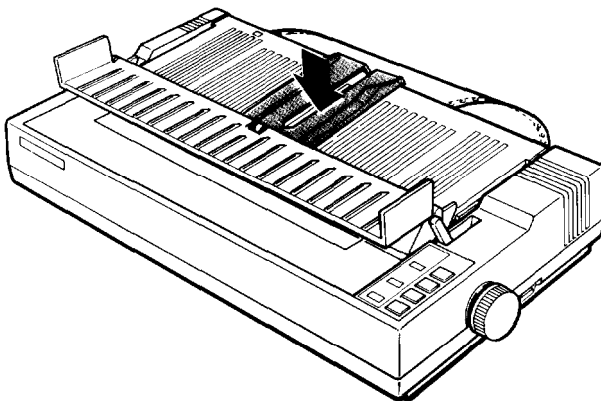

**Caution:** When using continuous paper, always make sure that the edge guides are pushed together.

11. Close the printer cover and turn on the printer.
12. Press the LOAD/EJECT button to feed the paper to the loading position. The printer remembers this position and advances each page to the same position.
13. Press the ON LINE button to put the printer on line so that it can accept data.

If you find that your word processing or other application program prints too high or too low on the page or is printing on the perforations, check the loading position. If you need to adjust this position, you can use the micro-adjustment feature. This feature gives you precise control over the position of your paper by allowing you to feed the paper forward or backward in 2/216-inch increments. For more information, see the section on micro-adjustment later in this chapter.

When using continuous paper, you can also choose the short tear-off feature to give you added paper handling capabilities. This feature automatically feeds the paper forward so that you can tear it off at its perforation. The printer then reverses the paper feed so you can resume printing at the loading position. Short tear-off makes it easier to detach printed pages and saves the blank pages that are usually lost between printing jobs. See the section on short tear-off later in this chapter for details.



**WARNING:** If you need to adjust the loading position, always use the micro-adjustment feature. Never advance the paper using the platen knob while the printer is turned on.

## Positioning your continuous paper supply

Three common ways of positioning your printer and continuous paper supply are shown below.

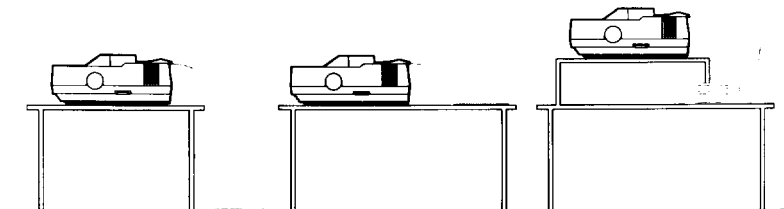

It's important to keep your paper supply aligned with the tractor **so that** the paper feeds smoothly into the printer.

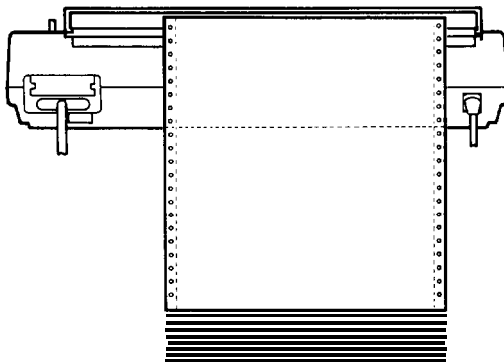

## Switching Between Continuous and Single Sheets

Even with continuous paper loaded in the printer, you can easily switch to single sheet printing without removing **the continuous paper from the tractor**. To switch from continuous paper to single **sheets**, follow the steps below.

1. Open the printer cover and press the **ON LINE** button to take the printer off line.

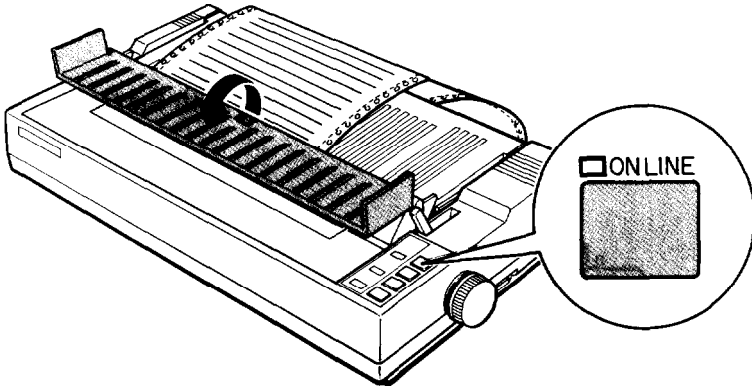

2. Remove your printed document. If you are **not** using the short tear-off function, press the **FORM FEED** button to advance your document to a **point where it can be removed**.

**Note:** To avoid feeding your continuous paper backward more than is necessary, always make sure that you tear off the printed document before removing paper with the **LOAD/EJECT** button.

3. Press the **LOAD/EJECT** button to feed the continuous paper backward out of the printer and into a standby position. The paper is still attached to the tractor, but is no longer in the paper path. The **PAPER OUT** light comes on when the paper is completely out of the paper path.

**Note:** Pressing the **LOAD/EJECT** button **once** may not feed the paper back enough to reach a standby position. If the **PAPER OUT** light does not come on, press the **LOAD/EJECT** button again. With normal continuous paper, you **can press the LOAD/EJECT** button up to three times. (With continuous paper narrower than six inches, you can press the **LOAD/EJECT** button only once.)

4. Push the paper release lever back to the single sheet position.

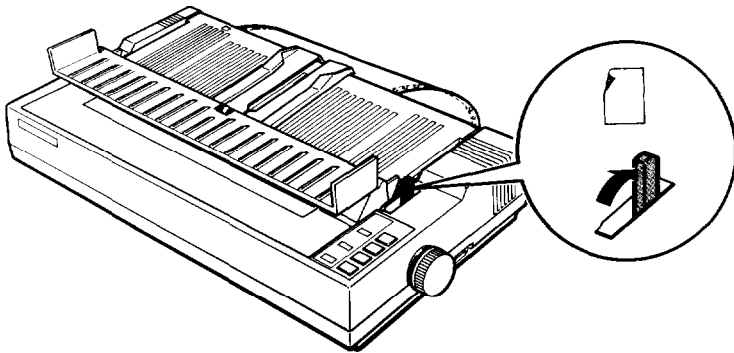

5. Stand the paper guide upright, and adjust the edge guides to roughly match the width of your paper.

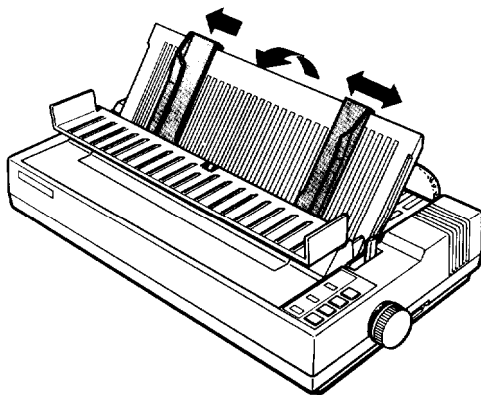

6. Close the printer cover. Next, slide the paper between the edge guides until it meets resistance. At this point, the PAPER OUT light turns off.

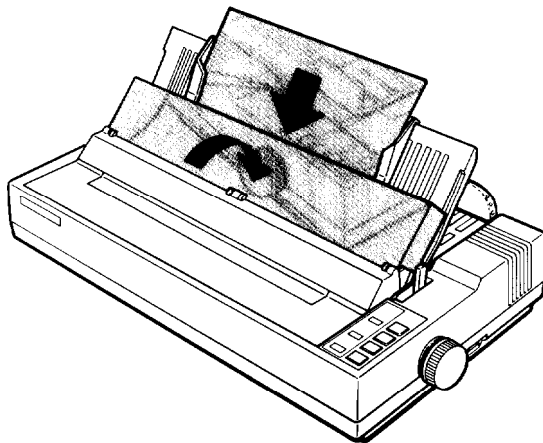

7. Press the LOAD/EJECT button to automatically feed the page to the loading position.

8. Press the ON LINE button to put the printer on line.

### Switching back to continuous paper

To switch back to printing with continuous paper, first eject the single sheet of paper and take the printer off line.

1. Open the printer cover. Lower the paper guide onto the back of the printer.

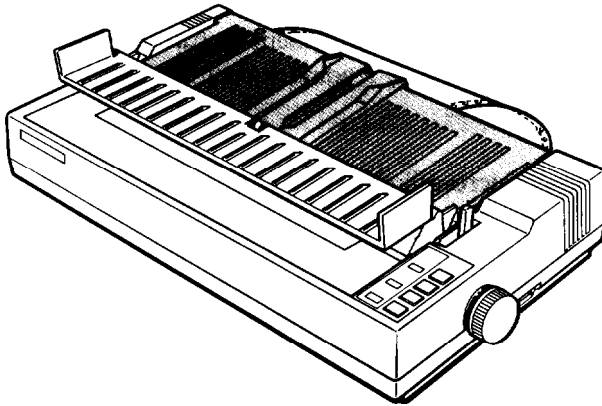

2. Pull the paper release lever forward to the continuous paper position.
3. Press the LOAD/EJECT button to feed the paper to the loading position.
4. Press the ON LINE button to put the printer on line.

## Adjusting the Loading Position

The loading position is the position of the paper when it has been automatically loaded by the printer. This position is important because it determines where the printing begins on the page. If the printing is too high or too low on the page, you need to change the loading position using the micro-adjustment feature described in the next section.

Until the loading position is reset, the printer remembers the position and uses it as a reference point for feeding the paper.



**WARNING:** If you need to adjust the loading position, always use the micro-adjustment feature. Never use the platen knob for paper feeding except in case of a paper feeding problem.

Once you have used micro-adjustment to change the loading position of continuous paper, the printer remembers that position even after it is turned off. However, when you use micro-adjustment to change the loading position of single *sheet* paper, the printer does not remember this position after the power is turned off. When the power is turned back on, the loading position returns to its factory setting.

## Using Micro-Adjustment

The micro-adjustment feature moves the paper  $2/216$ th of an inch at a time to make fine adjustments to the loading or short tear-off positions. Micro-adjustment only works immediately after you load paper or use the short tear-off function. You can use micro-adjustment only when the printer is on line and the ON LINE indicator light is flashing.

After you adjust the tear-off position or after you adjust the loading position for continuous paper, the printer remembers that position even after it is turned off, reset, or initialized. However, when you adjust the loading position for single-sheet paper, the printer does not remember the new position after the power is tuned off.

This section describes using micro-adjustment to change the loading position, but you can adjust the short tear-off position the same way. See the next section on using short tear-off for more information.

To perform micro-adjustment of the loading position, first load your paper, and then press the **ON LINE** button to put the printer on line. The **ON LINE** indicator light starts to flash. While this light is flashing, you can use the **FORM FEED** and **LINE FEED** buttons for micro-adjustment.

Press the **FORM FEED** button to feed the paper forward or the **LINE FEED** button to feed the paper backward.

Each time you press the button, the paper moves  $\frac{2}{216}$  of an inch. If you hold the button down, the paper moves continuously in  $\frac{2}{216}$ -inch increments.

When the paper reaches the factory-set loading position, the printer beeps and micro-adjustment feeding pauses for a moment before continuing. You can use this factory setting as a reference point when adjusting the printer's loading position. When the paper reaches either the minimum or maximum top margin, the printer beeps and the paper stops moving.

## Using Short Tear-Off

When you are finished printing, the short tear-off feature automatically feeds the perforation of the continuous paper to the tear-off edge of the printer cover so that you can tear off the last sheet. When you resume printing, the printer reverses the paper back to the loading position so that you can use all of the next sheet.



**WARNING:** Never use short tear-off with labels.

To use short tear-off, first turn off the printer and turn DIP switch 1-5 off. (See the section on setting DIP switches in Chapter 3.) Then load continuous paper as usual, but leave the rear section of the printer cover open so that you can use the cover as a tear-off edge.

The short tear-off function operates as follows:

1. The perforation at the end of the last printed page feeds to the tear-off edge of the printer cover.
2. Tear off the page using the printer cover's tear-off edge.

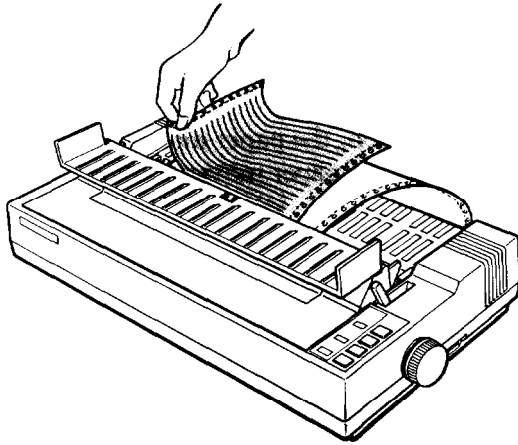

3. If you need to adjust the position of the perforation to meet the tear-off edge, use micro-adjustment. This feature adjusts your tear-off position only when you use it immediately after short tear-off. First, make sure that the printer is on line and the ON LINE indicator light is flashing. Then, adjust the position in  $\frac{2}{216}$ th-of-an-inch increments by pressing the FORM FEED button to feed the paper forward or the LINE FEED button to feed it backward.

After micro-adjustment, the new tear-off position is reset and remains valid even after the printer is turned off, reset, or initialized.

4. When you resume printing after tearing off the sheet, the paper automatically feeds backward to the loading position before printing begins.

You can leave the short tear-off feature turned on (DIP switch 1-5 off) even when you are using single sheets. When you move the paper release lever to the single sheet position, short tear-off is disabled.

## Printing on Special Paper

In addition to using single sheets and continuous paper, your printer can also print on a wide variety of paper types, including multi-part forms and labels. You can even feed envelopes, either manually or with the optional cut sheet feeder. Before printing on these special types of paper, however, you need to adjust the paper thickness setting.

### The paper thickness lever

To accommodate various thicknesses of paper, the FX printer is equipped with a paper thickness lever that can be set to eight positions. These positions are identified by a scale on the printer frame next to the lever.

Before changing the paper thickness setting, first make sure the power is off and then remove the printer cover.



**WARNING:** If you've been using the printer just before opening the printer cover, be careful not to touch the print head because it may be hot.

Select the paper thickness you want according to the figure below. For normal use, the lever should always be set to position 2 on the scale.

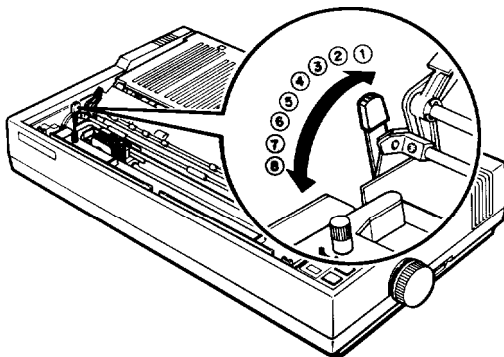

For printing on special types of paper, see the table below. It gives you general guidelines for selecting the right paper thickness lever position to match your paper.

Paper Type	Lever Position
Paper (single sheets or continuous)	2
Thin paper	2
Multi-part paper	<b>3</b>
3-sheet	<b>3</b>
4-sheet	4
Labels	3
Envelopes	
Air mail	3 or 4
Plain	<b>5</b>
Bond (20 lb.)	<b>5</b>
Bond (24 lb.)	6

Always return the lever to position 2 when you go back to printing on ordinary paper. Continuous printing with the lever set at a position higher than 2 can shorten the life of the print head.



**WARNING:** Printing past the edge of envelopes, multi-part forms, labels, or thick paper can damage the print head.

When you print on anything thicker than normal paper, such as envelopes or multi-part forms, be absolutely sure that your printing stays within the printable area of the paper. See page 2-20 and Appendix A for more about the printable area of the paper.

### Multi-part forms

Your printer can also use continuous multi-part forms. These multiple forms should have no more than four parts including the original.

Note: Multi-part forms should not be used with the single sheet feeding system or the optional cut sheet feeder.

You load continuous multi-part paper the same way that you load continuous paper. See the section on loading continuous paper in this chapter for details. The only difference is that you need to adjust the paper thickness lever to suit the thickness of your paper before loading. See the table above for the correct paper thickness setting.

## Labels

If you need to print labels, always choose the type mounted on a continuous base sheet provided with sprocket holes for use with the tractor. If you attempt to print labels using the single-sheet feeding system, labels on a shiny base sheet almost always slip a little.

You load labels the same way that you load continuous paper. See the section on loading continuous paper in this chapter for details. The only difference is that you need to adjust the paper thickness lever to match the thickness of your labels. See the table above for the correct paper thickness setting.

To remove labels, tear off at a perforation behind the push tractor. Then take the printer off line and use the FORM FEED button to eject the labels.



**WARNING:** Never feed the labels backward through the printer. Labels can easily come off the backing and jam the printer. Therefore, never use the LOAD/EJECT button to eject labels or to feed labels backward to the standby position. Also, never use the short tear-off feature with labels. If a label does become stuck in the printer mechanism, take the printer to a qualified service person. Since labels are especially sensitive to temperature and humidity, always use them under normal operating conditions.

## Envelopes

You can print on a variety of envelopes, including air mail, plain, or bond. To feed envelopes individually, use the single sheet loading feature. First, set the paper thickness lever as indicated in the table above. Then, follow the single sheet loading instructions at the beginning of this chapter.

You can also feed envelopes with the optional cut sheet feeder. See the section on the cut sheet feeder in Chapter 7. Before loading envelopes into the cut sheet feeder, you need to adjust the paper thickness lever. See **the** table showing envelope types and recommended lever positions on page 2-18.

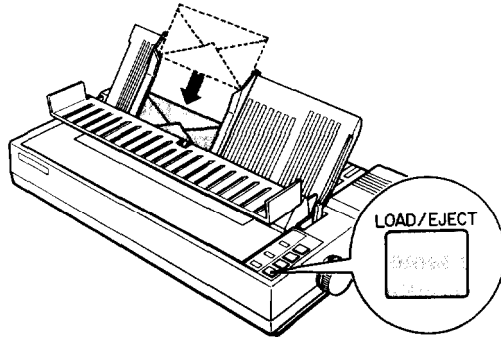

**WARNING:** When printing on envelopes, be sure that your application program settings keep the printing entirely within the printable area of the envelopes as **shown below**.

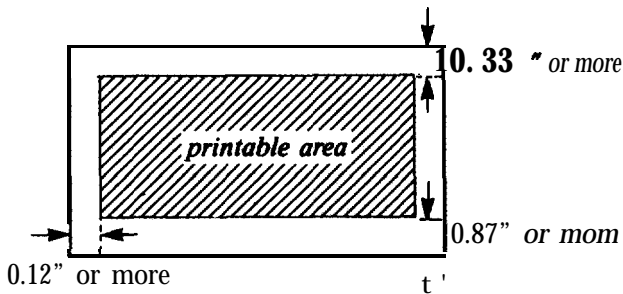

**To make sure that** the printing fits within this area, always print a test on a single sheet of paper before printing on envelopes.

## Chapter 3

---

# Using the Printer

Operating the Control Panel .....	3-2
Lights .....	3-2
Buttons .....	3-3
SelecType .....	3-4
Other control panel features .....	3-5
Setting the DIP Switches .....	3-5
DIP switch functions .....	3-6
Selecting Typestyles .....	3-10
Using SelecType .....	3-11
Character fonts .....	3-11
Characters per inch .....	3-12
Condensed mode .....	3-12
If SelecType does not work .....	3-13
Enhancing Your Printing .....	3-13
Character size .....	3-13
Emphasized and double-strike printing .....	3-14
Italic printing .....	3-15
Underlining .....	3-15
Superscripts and subscripts .....	3-15
Selecting typestyles with Master Select .....	3-15

# Operating the Control Panel

The buttons on the control panel let you control many of the printer settings. The control panel also has indicator lights so you can check the current status of the printer's various settings.

## Lights

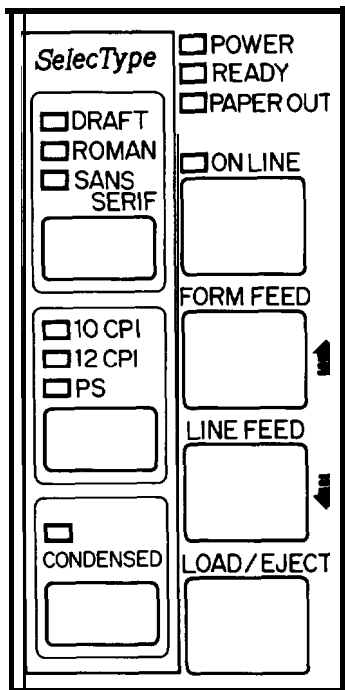

### POWER

On when the power switch is on and power is supplied.

### READY

On when the printer is ready to accept input data. Flickers when receiving data.

### PAPER OUT

On when the printer is out of paper or when continuous paper is in the standby position.

### ON LINE

On when the printer is on line and ready to accept data. This light flashes immediately after you load paper or use short tear-off to indicate that micro-adjustment can be used.

# Buttons

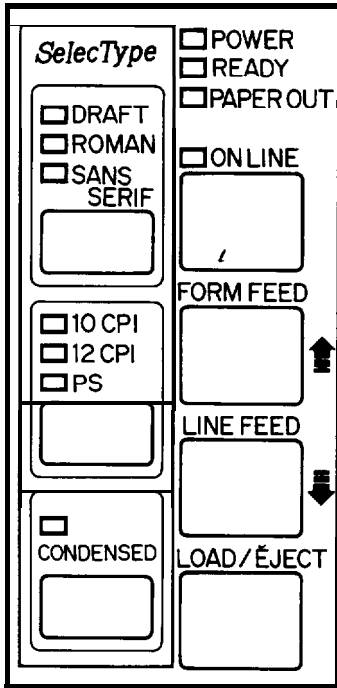

## ON LINE

This button controls the printer's on line/off line status. When the printer is on line, the printer can receive and print data from the computer.

## FORM FEED

When the printer is off line, press this button to eject a single sheet of paper or advance continuous paper to the top of the next page. When the printer is on line, you can use the micro-adjustment feature by pressing this button to advance the paper.

## LINE FEED

When the printer is off line, press this button to feed the paper one line, or hold it down to feed the paper continuously. When the printer is on line, you can use the micro-adjustment feature by pressing this button to reverse the paper.

## LOAD/EJECT

When the printer is off line, press this button to load paper if paper is not loaded, or to eject it if paper is loaded. (Single sheet paper is ejected forward and continuous paper is ejected backward.)

## SelectType

The **settings** you select using the SelectType panel remain valid even after you turn off, reset, or initialize the printer.

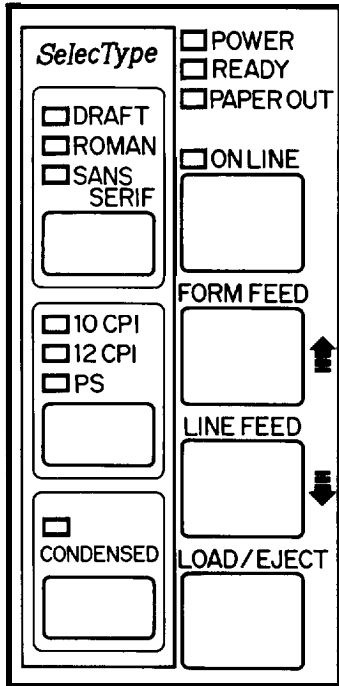

### FONT

Press this button to select draft, near letter quality Roman, or near letter quality Sans Serif. The indicator light shows which font has been selected.

### CHARACTERS PER INCH

Press this button to select the characters per inch (cpi). You can choose 10 CPI, 12 CPI, or PS (proportional spacing). The indicator light shows the selected character spacing.

### CONDENSED

Press this button to select either condensed or normal printing. The light is on when the printer is in condensed mode. In this mode, all characters are approximately 60% of their normal width.

**Note:** Proportional spacing and condensed mode cannot be combined. If you select both, only proportional spacing works.

## Other control panel features

The control panel of the FX also gives you access to several special functions.

- Self test                    By holding down the **FORM FEED** or **LINE FEED** button while you turn on the printer, you can start the printer's self test. This prints out the DIP switch settings and the characters in the printer's ROM (Read Only Memory). See **the** section on the self test in Chapter 1 for more information.
- Micro-  
adjustment                    By pressing the **FORM FEED** and **LINE FEED** buttons immediately after loading paper or using short tear-off, you can make fine adjustments to the loading and short tear-off positions. See the section on micro-adjustment in Chapter 2 for more information.
- Data dump                    By holding down both **the FORM FEED** and **LINE FEED** buttons while you turn **on** the printer, you can turn on **the** data dump mode. This feature allows advanced users to diagnose many problems. See the section **on** the data dump mode in Chapter 6 for more information.

## Setting the DIP Switches

By changing the settings of the two sets of DIP switches behind and below the platen knob, you **can** control various printer features, such as the character set and page length. These new settings become valid whenever the printer is turned **on**, reset, or initialized.

Before you set the DIP switches, turn off the printer. Then use a pointed instrument, such as the tip of a pen or pencil, to move the switch to either **the on** or off position. The new settings become valid when you turn on the printer.

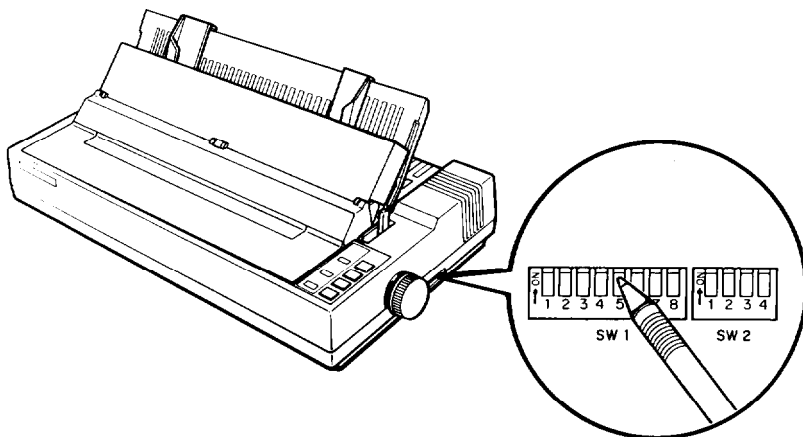

## DIP switch functions

The tables below describe the DIP switch functions. The page numbers refer you to the page on which each printer feature is described. The shaded settings are the preset factory settings.

### DIP Switch 1

SW	Description	ON	OFF	Page
1-1	Default character set	User-defined	ROM	3-7
1-2	Zero character	Slashed	Not slashed	3-7
1-3	Character table	Graphic	Italic	3-7
1-4	Printer mode	IBM emulation	Epson ESC/P	3-8
1-5	Short tear-off mode	OFF	ON	3-8, 2-15
1-6	international character set	See table below		3-9
1-7				
1-8				

### DIP Switch 2

SW	Description	ON	OFF	Page
2-1	Page length	12 inch	11 inch	3-9
2-2	Cut sheet feeder mode	On	Off	3-10
2-3	1 -inch skip over perforation	On	Off	3-10
2-4	Automatic line feed	On	Off	<b>3-10</b>

Country	SW1-6	SW1-7	SW1-8
USA	On	On	On
France	On	On	Off
Germany	On	Off	On
UK	On	Off	Off
Denmark	Off	On	On
Sweden	Off	On	Off
Italy	Off	Off	On
Spain	Off	Off	Off

## Default character set

When DIP switch 1-1 is on, the user-defined character set is the default. User-defined characters are maintained in printer memory even when the power is turned off, so the user-defined character set can be selected simply by setting this switch to on. However, when this switch is on, new user-defined characters cannot be defined. See Chapter 4 for more information on user-defined characters. This switch is effective only in the Epson ESC/P mode.

## Zero character

When DIP switch 1-2 is on, the printer prints slashed zeroes (0). When the DIP switch is off, the printer prints open zeroes (0). This is useful for clearly distinguishing between uppercase O and zero when printing such items as program lists.

## Character table

When DIP switch 1-3 is on, the Epson Extended Graphics character table is selected. **When** it is off, the italics character table is selected. The Epson Extended Graphics character table contains international accented characters, Greek characters, and character graphics for printing lines, comers, and shaded areas. If you have an IBM® computer or an IBM compatible, select the Epson Extended Graphics table when you wish to print the character graphics as they are displayed on the screen. Since the character table setting affects only half of the character table, you can



## International character set

Selecting an international character set provides you with the characters used in other languages. To obtain the desired international character set, set switches 1-6, 1-7, and 1-8 according to the DIP switch table on page 3-7. The following table shows the characters that differ in each international character set.

### *International character sets*

	35	36	64	91	92	93	94	96	123	124	125	126
0 USA	#	\$	@	[	\	]	^	`	{		}	~
1 France	#	\$	à	°	ç	§	^	`	é	ù	è	.
2 Germany	#	\$	§	Ä	Ö	Ü	^	`	ä	ö	ü	ß
3 UK	£	\$	@	[	\	]	^	`	{		}	~
4 Denmark I	#	\$	@	Æ	Ø	Å	^	`	æ	ø	å	~
5 Sweden	#	¤	É	À	Ö	Å	Ü	é	ä	ö	å	ü
6 Italy	#	\$	@	·	\	é	^	`	à	ò	è	ì
7 Spain I	₧	\$	@	ı	Ñ	¿	^	`	ñ	ı	}	~
8 Japan	#	\$	@	[	¥	]	^	`	{		}	~
9 Norway	#	¤	É	Æ	Ø	Å	Ü	é	æ	ø	å	ü
10 Denmark II	#	\$	É	Æ	Ø	Å	Ü	é	æ	ø	å	ü
11 Spain II	#	\$	á	ı	Ñ	¿	é	`	ı	ñ	ó	ú
12 Latin America	#	\$	á	ı	Ñ	¿	é	ü	ı	ñ	ó	ú

The countries numbered 8 through 12 are available only through the ESC R software command. See the Command Summary in Chapter 8. Also, in IBM emulation mode (DIP switch 1-4 on), a character set containing international characters (CG character table 2) is selected whenever any one of DIP switches 1-6, 1-7, or 1-8 is set to off. If all three switches are on, CG character table 1 is selected. See Appendix B.

## Page length

When DIP switch 2-1 is on, the page length is set to 12 inches. When it is off, the page length is 11 inches. Other page lengths can be set with the ESC C and ESC CO commands. See the Command Summary in Chapter 8.

## Cut sheet feeder mode

When DIP switch 2-2 is on, you can use your printer's optional cut sheet feeder. See Chapter 7 for more information on using a cut sheet feeder with your printer.

## Skip over perforation

When DIP switch 2-3 is on, a one-inch margin is provided between the last line printed on one page and the first line printed on the next page. When using continuous paper, this feature causes **the** printer to stop printing, skip over the perforation, and then resume printing. If you adjust your loading position correctly, you can get half of the margin at the bottom of one page and half at the top of the next page. See the section on adjusting the loading position later in this chapter.

**Note: Most application programs take care of the top and bottom margins. Only use skip over perforation if your program does not provide these margins.**

## Automatic line feed

When DIP switch 2-4 is on, a carriage return code (CR) causes an automatic line feed. When it is off, line feeds occur only when the printer receives line feed codes (LF). Since some computers and application programs automatically add line feeds to carriage returns, the setting you use depends on your computer and application program.

## Selecting Typestyles

Your printer can produce a wide range of typestyles by combining different character fonts, pitches, widths, and other enhancements. These features can be selected by using the SelecType feature on your control panel or by using software commands. This section describes only the features controlled by SelecType. To use software commands, see the section on computer-printer communication in Chapter 4 and the Command Summary in Chapter 8.

## Using SelectType

You can use the SelectType control panel to choose fonts, pitches, and condensed printing. The settings you select using the SelectType panel remain valid even after the printer is turned off, reset, or initialized. However, commands from your software application program temporarily override the SelectType settings.

### Character fonts

The FX-850 and FX-1050 have three built-in character fonts:

#### DRAFT

```
!"#$%&'()*+,-./0123456789:;<=>?@ABCDEFGHIJK  
LMNOPQRSTUVWXYZ[\]^_`abcdefghijklmnopqrstuv  
wxyz{;}~
```

```
We've just seen your excellent ad for  
miniature zebras in a recent back issue of  
Trader's Times. What is the price of these  
items for quantities of more than one gross?
```

#### ROMAN

```
!"#$%&'()*+,-./0123456789:;<=>?@ABCDEFGHIJK  
LMNOPQRSTUVWXYZ[\]^_`abcdefghijklmnopqrstuv  
wxyz{;}~
```

```
We've just seen your excellent ad for  
miniature zebras in a recent back issue of  
Trader's Times. What is the price of these  
items for quantities of more than one gross?
```

#### SANS SERIF

```
!"#$%&'()*+,-./0123456789:;<=>?@ABCDEFGHIJK  
LMNOPQRSTUVWXYZ[\]^_`abcdefghijklmnopqrstuv  
wxyz{;}~
```

```
We've just seen your excellent ad for  
miniature zebras in a recent back issue of  
Trader's Times. What is the price of these  
items for quantities of more than one gross?
```

The draft mode uses fewer dots per character for high-speed printing. This makes draft ideal for rough drafts and editing work.

Roman and Sans Serif are near letter quality (NLQ) fonts. Near letter quality takes a little longer to print but produces nicely formed characters suitable for most documentation requirements.

### Characters per inch

For each of the three built-in fonts, you can choose a character size of 10 or 12 characters per inch (cpi), or proportional spacing.

The following printout compares the different types of spacing.

```
This is Roman printing in 10 cpi.  
This is Roman printing in 12 cpi.  
This is Roman printing in proportional.
```

In the 10 and 12 cpi modes, each character is given the same amount of space. However, in the proportional mode, spacing varies from character to character. Therefore, a narrow letter like the lowercase i receives less space than a wide letter like the uppercase W.

### Condensed mode

In addition to the two pitches and proportional spacing, you can use the condensed mode to change the character size. In the condensed mode, characters are approximately 60% of the width of normal characters. Condensed printing is very useful for spreadsheets and other applications where you need to print the maximum amount of information on a page. Both 10 and 12 cpi can be condensed, but proportional spacing cannot.

The printout below compares normal 10 cpi with condensed 10 cpi.

```
This is 10 cpi Roman printing.  
This is condensed 10 cpi Roman printing.
```

Note: Proportional spacing and condensed mode cannot be combined. If you select both, only proportional spacing works.

### **If SelecType does not work**

Some application programs are designed to control all typestyle functions. These programs cancel all previous typestyle settings by sending certain software commands before printing. Because these commands cancel SelecType settings, you should use the program's print options function instead of SelecType to select your typestyles. Therefore, if SelecType does not work with a particular application program, consult the software manual for information on selecting typestyles. Also, see the section on using the FX with application software in Chapter 4.

## **Enhancing Your Printing**

SelecType controls the printing style of a whole document. Software commands, on the other hand, can change anything from a single character to the entire document. By using software commands, you can obtain many different printing effects with the FX printer, from arranging the text on the page to giving extra emphasis to particular words and phrases. This section shows you the features you may want to select with your software. Once you have read about the features, you can find their commands in the Command Summary in Chapter 8. Also, see the section on computer-printer communication in Chapter 4 for more information on sending commands to the printer.

### **Character size**

Besides 10 and 12 cpi, condensed printing, and proportional spacing, software commands also offer two other options: double-wide and double-high printing.

The double-wide mode doubles the width of any size characters. This mode is useful for such purposes as emphasizing headings in reports and making displays, but is usually not suitable for large amounts of text.

T h i s   i s   d o u b l e - w i d e -

Another mode for headings and other special uses is double-high:

This is double-high.

Because of its height, you must leave a blank line above a line of double-high printing. Otherwise, the double-high letters will overlap the letters on the previous line.

Double-wide and double-high can be combined to obtain even more impressive printing results:

D o u b l e - h i g h   d o u b l e - w i d e

Widening or narrowing the characters also widens or narrows the spaces between words and letters. Because word processors usually create a left margin by printing spaces, you may need to change the number of characters on a line to keep the margins correct if you change widths. For example, a left margin of **10** characters at **10** cpi is the same as a five-space margin using double-wide characters.

### **Emphasized and double-strike printing**

Emphasized and double-strike printing give your documents added emphasis. In emphasized mode, the FX prints each character twice as the print head moves across the paper, with the second printed slightly to the right of the first. This process produces darker, more fully formed characters.

In double-strike mode, the printer prints each character twice, the second time slightly below the first, making the text bolder. For even greater boldness, you can combine emphasized and double-strike. (Double-strike cannot be combined with NLQ mode, however.)

## Italic printing

You can use italic characters for special emphasis or as an alternative typeface. ESC 4 turns on the italic mode even if the current DIP switch setting is set to the Epson Extended Graphics character table.

*This sentence is in italics.*

## Underlining

The underline mode automatically underlines any piece of text. It underlines spaces, subscripts, and superscripts. (The printer does not, however, underline horizontal tabs.)

## Superscripts and subscripts

Superscripts and subscripts can be used for printing footnote numbers and mathematical formulas. The example below combines underlining, superscripts, and subscripts in a mathematical formula.

a v e r a g e = ( a <sup>1</sup> + . . . . . + a <sub>n</sub> )

## Selecting typestyles with Master Select

Your printer has a special command called Master Select that allows you to choose many possible combinations of nine different modes. To send Master Select codes to the printer, you must first choose the mode combination you want. The modes you can choose from are 10 cpi, 12 cpi, proportional, condensed, emphasized, double-strike, double-wide, italics, and underline.

The format of the Master Select code is shown below:

ASCII:	ESC	1	n
Decimal:	27	33	n
Hexadecimal:	1B	21	n

To send the Master Select codes to your printer in a decimal format, for example, you send the codes 27, 33, and then whatever value you choose for the variable  $n$ .

The variable  $n$  is a number that identifies the typestyle or combination of typestyles. To find the value of  $n$ , look at the Master Select table below and add up either the decimal or hexadecimal numbers for the features you want.

*Master Select Table*

Feature	Dec.	Hex.
10 cpi	0	00
12 cpi	1	01
proportional	2	02
condensed	4	04
emphasized	8	08
double-strike	16	10
double-wide	32	20
italics	64	40
underline	128	80

For example, if you want to print a title using double-wide 12 cpi characters in double-strike mode, you would add these three decimal numbers together to calculate the value of  $n$ :

12 cpi	1
Double-strike	16
Double-wide	32
	$n = 49$

After calculating the value of n, you use the Master Select command to send the value to the printer. To send the Master Select command for double-wide, 12 cpi, and double-strike, you would use the decimal codes 27, 33, and 49.

ASCII:	ESC	!	1
Decimal:	27	33	49
Hexadecimal:	1B	21	31

Consider these things when you use the Master Select command:

- Master Select cancels any of the listed features that you do not set. For example, if you have already set 12 cpi, and you try to use Master Select to set emphasized double-strike only, the character width is reset to 10 cpi.
- Proportional overrides 10 cpi, 12 cpi, and condensed.
- Double-strike cannot be combined with NLQ mode.

Print quality and font are not part of Master Select and must be set separately, using either SelecType or the ESC x and ESC k commands.

The method you use to send the Master Select codes to the printer is determined by your application software. For more information on sending commands to your printer, see the Computer-Printer Communications section in Chapter 4 and the Command Summary in Chapter 8.

# Using Software and Graphics

Using the FX with Application Programs .....	4-2
Using printer selection menus .....	4-2
A quick test .....	4-3
Using word processors .....	4-3
Using spreadsheets .....	4-3
Using graphics software .....	4-5
Computer-Printer Communication .....	4-5
Escape sequences .....	4-6
Printer commands .....	4-6
Using the Command Summary .....	4-7
Sending printer commands from within your software program .....	4-7
Dot Graphics .....	4-8
The print head .....	4-9
Pinlabels.. .....	4-10
Graphics commands .....	4-11
Graphics programming .....	4-12
User-Defined Characters .....	4-19
Defining your own characters .....	4-20

## Using the FX with Application Programs

Now that you've set up and tested the printer, you need to start using it with your application programs.

Most application programs let you specify the type of printer you're using so that the program can take full advantage of the printer's features. Many programs provide an installation or setup procedure that presents a list of printers to choose from. If your application program has a printer selection menu, use the instructions below.

### Using printer selection menus

If your software has a printer selection menu, simply choose FX-850 or FX-1050. If the menu does not list either of these printers, choose one of the following. They are listed in order of preference.

FX-850	Fx-1050
FX-86e	FX-286e
EX-800	EX-1000
FX-85	FX-286
FX-80 +	FX-185
FX-80	FX-100 +
FX	FX-100
LX	FX
MX	LX
Epson printer	MX
Draft printer	Epson printer
	Draft printer

If you plan to use the IBM emulation mode, choose IBM Proprinter (if you have an FX-850), IBM Proprinter XL (if you have an FX-1050), IBM Graphics printer, or IBM printer, in that order of preference.

Note: If your application program does not list the FX-850 or FX-1050, you may want to contact the **software** manufacturer to see if an update is available.

## A quick test

After setting up your application program, print a sample document to make sure the program and the FX are communicating properly. If the document doesn't print correctly, recheck the program's printer selection and installation procedure. If you're still having trouble printing, consult the troubleshooting section in Chapter 6.

## Using word processors

Word processors usually let you use a fixed set of printer features by placing markers around the text to be altered. When the document is printed, the markers are recognized and translated into suitable commands for your printer. On your screen some programs show the markers; others display the text as it will appear—for example, in bold or italics. This method is normally restricted to features that can be found on almost all printers, such as bold and underlining.

Some word processing programs also let you insert printer commands in your text. These commands may or may not be visible on your screen. This method has the advantage of allowing you to use any printer command, not just a limited set. To make use of it, however, you need to understand how to use your printer's commands. Check the manual for your word processor to see if you can place printer commands in your text, and then see the section in this chapter on computer-printer communications.

## Using spreadsheets

Although spreadsheets seldom use as many printing styles as word processors, they do have some very specific requirements.

If your spreadsheet program provides a list of printers, use the list on page 4-2 to find the proper selection. If your spreadsheet doesn't have a printer setup routine, read the program's manual carefully for information on printing.

A major concern for printing spreadsheets is the width of the printer. The FX-850 is an 80-column printer, and the FX-1050 is a 136-column printer. You can, however, increase the number of characters on a line by selecting 12 cpi, condensed mode, or both from the SelecType control

panel. The table below shows you many characters you can fit on a line using these options. If your spreadsheet asks the number of columns your printer can print, decide which mode you will use and supply the appropriate number from this table.

Typestyle	FX-850	FX-1050
Normal (10 cpi)	80	137
12 cpi	96	163
Condensed	137	233
12 cpi condensed	160	272

Unlike word processors, spreadsheet programs usually don't let you change printer commands within a spreadsheet. Instead, one style or mode of printing is used for the whole spreadsheet. With the FX, there are two main ways of sending commands to control the printing of a spreadsheet. The first method is to choose condensed from the SelectType control panel.

For the second method, look in the manual for your spreadsheet to find out how to send printer commands. Then look in the Command Summary in Chapter 8 to find the proper codes to send.

For example, your spreadsheet might use a "setup string" to send printer commands. To prepare a setup string for 12 cpi condensed, you would look up the proper command in the Command Summary. The command for 12 cpi is ESC M, and the command for condensed is SI. Because most spreadsheets use the decimal equivalent for the commands, (also given in the Command Summary), a setup string for 12 cpi condensed might look like this:

/027/077/015

The number 027 is for the escape code, 077 is for M, and 015 is for SI (condensed).

## Using graphics software

The FX is capable of producing finely detailed graphic images. Although the section on graphics later in this chapter gives specific information on the graphics commands, the easiest way to take advantage of the FX's capabilities is with one of the many graphics programs available.

When buying graphics software, always make sure the program has an option to print on an FX printer. Any program with an option for an FX printer should give excellent results, using different dot densities to produce a realistic scale of grays.

Most graphics programs have a printer selection procedure, in which case you should check the lists on page 4-2 to find the proper selection.

## Computer-Printer Communication

Your computer communicates with your printer using a standardized set of numbered codes called ASCII codes (American Standard Code for Information Interchange). When you press the letter A on the keyboard, it is translated into the ASCII code for A, transmitted to a peripheral device such as your computer screen or your printer, and then converted back into the letter A.

There are ASCII codes for all the letters in the alphabet, both uppercase and lowercase letters, and for the numbers 0 through 9. The ASCII set of codes also includes most punctuation marks and some codes that control printer functions.

In the Command Summary in Chapter 8, each code is expressed three different ways: as an ASCII character, as a decimal number, and as a hexadecimal (base 16) number. For example, the uppercase letter A is represented as the ASCII character A, the decimal number 65, and the hexadecimal number 41. The numbering system you use depends on your software and your preferences.

All letters, numbers, and punctuation marks are assigned decimal numbers from 32 through 255. ASCII codes with decimal values of less than 32 are called control codes, because they control the operation of

your printer and other peripherals. These ASCII characters do not usually have corresponding keys on the keyboard and cannot be printed as characters by your printer.

## Escape sequences

Although there are more than 30 control codes available to control the operation of your printer, many more codes are required to run today's sophisticated printers. Therefore, ASCII codes are grouped in sequences to represent certain functions. These code sequences use the ASCII codes with decimal values of 32 through 255, normally reserved for characters and punctuation, to control printer functions. This is done by first sending a standard code to tell the printer that the codes that follow are to be used as control codes, not as characters or punctuation.

The standard code that is sent at the beginning of one of these code sequences is the Escape code, decimal value 27. Any sequence of codes starting with the Escape code is called an Escape sequence. You will probably see Escape written in different ways—such as ESC, `ESC`, and `ESCape`—in various manuals. In this manual it is in the form of `ESC` when used within a command.

## Printer commands

In order for the printer to recognize the instructions it receives, ASCII codes must be sent in a specific format, called a command. An Escape sequence is a command, as is any ASCII code or sequence of codes that instructs the printer to carry out a particular function. Your software continually sends commands to your printer and your computer screen. These commands instruct the printer to perform such actions as print in a particular typeface, feed the paper a certain amount after printing each line, and start printing on a particular spot on the page.

Some software programs let you send these commands yourself. This is a powerful feature because it allows you to enhance your text in ways that may not normally be available through the software. For example, many word processing programs do not offer italics. By inserting a command in your document, however, you can use italics anywhere you like. The

commands that your printer recognizes are listed in the Command Summary in Chapter 8 and on the Quick Reference card at the back of this manual.

## Using the Command Summary

The commands listed in the Command Summary in Chapter 8 consist of various combinations of ASCII codes. You can use either the ASCII characters or their decimal or hexadecimal equivalents. For example, the command to turn on subscript is ESC S1 in ASCII characters. The decimal format for this command is 27 83 01, and the hexadecimal format is 1B 53 01.

In the Command Summary, commands are grouped by the printer functions they control, such as character pitch, print enhancement, and graphics. You can also look up commands in the list of software commands in numerical order at the beginning of the Command Summary. This list gives you page number references for the commands.

Some commands include a variable, such as the letter *n*. For example, the command for selecting *or* cancelling double-high mode is ESC w *n*. When  $n = 1$ , double-high mode is turned on, and when  $n = 0$ , it is turned off. In the Command Summary, variables are printed in italics to distinguish them from ASCII characters.

## Sending printer commands from within your software program

How you format commands depends on the software program you are using. Some software programs accept only the decimal format, while others require certain punctuation. Some programs don't let you insert printer commands at all.

If your software does allow you to send commands to the printer, use the Command Summary to find the command you want to send. Your software manual should explain exactly what format and punctuation are required.

## Dot Graphics

The dot graphics mode allows your FX printer to produce pictures, graphs, charts, or almost any other pictorial material you can devise. Because many commercial software programs use graphics, you may be able to print pictures and graphs like the ones on this and the following page simply by giving your software a few instructions.

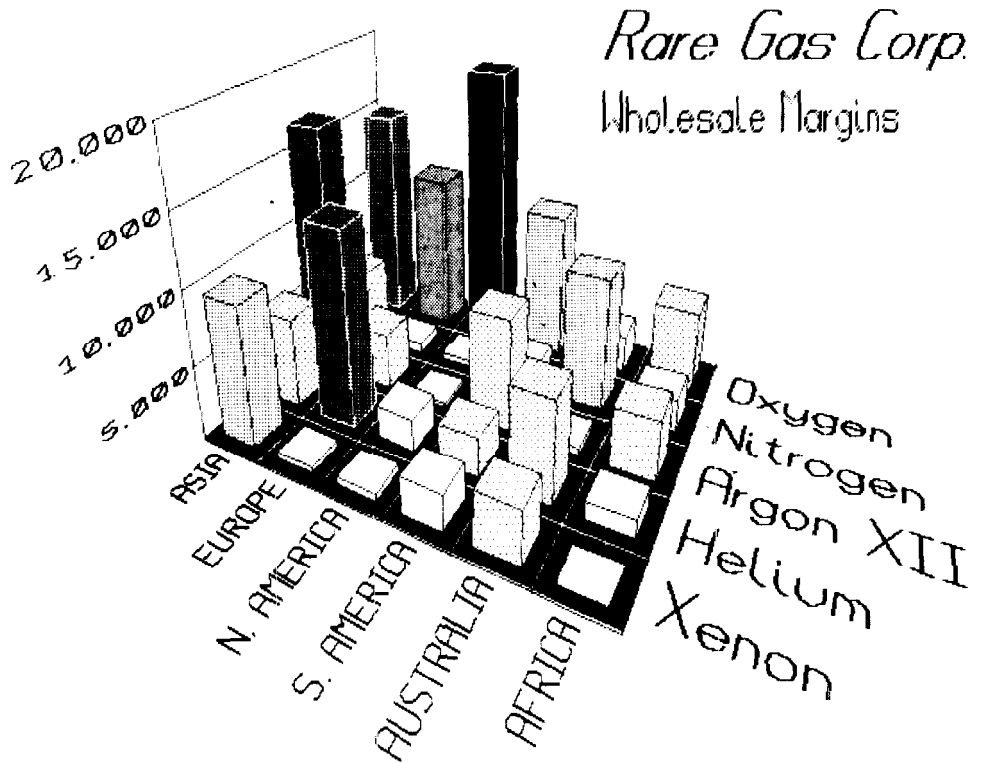



The quickest and easiest way to print graphics on your printer is to use a commercial graphics program. With such programs you usually create an image on your monitor and then give a command to send the image to the printer.

If you use commercial software that produces graphics, all you need to know about dot graphics is how to use the software. If, on the other hand, you wish to do your own programming or merely wish to understand how the FX prints graphics, read on.

### **The print head**

To understand dot graphics you need to know a little about how the FX's print head works.

The print head has nine pins. As the print head moves across the page, electrical impulses cause the pins to fire. Each time a pin fires, it strikes the inked ribbon and presses it against the paper to produce a small dot. As the head moves across the paper, the pins fire time after time in different patterns to produce letters, numbers, or symbols.

The print head is able to print graphics in addition to text because graphic images are formed on the FX about the same way that pictures in newspapers and magazines are printed. If you look closely at a newspaper photograph, you can see that it is made up of many small dots. The FX also forms its images with patterns of dots. The images printed by the FX can be as finely detailed as the ones at the beginning of this section.

In its main graphics mode the FX prints one column of dots for each code it receives, and it uses only the top eight of the nine pins. Therefore, your graphics program must send codes for dot patterns, one number for each column in a line. For each of those columns the print head prints the pattern of dots you have specified.

To print figures taller than eight dots, the print head makes more than one pass. The printer prints one line, then advances the paper and prints another, just as it does with text.

To keep the print head from leaving gaps between the graphics lines as it does between the text lines, the line spacing must be changed to eliminate the space between lines. With a change in line spacing, the FX can print finely detailed graphic images made up of adjacent lines, each no more than 8/72-inch tall.

Each pass of the print head prints one piece of the total pattern, which can be as tall or short and as wide or narrow as you desire. You don't have to fill the whole page or even an entire line with your graphics figures. In fact, you can use as little or as much space as you like for a figure and put it anywhere on the page.

### Pin labels

The graphics mode requires a method to tell the printer which pins to fire in each column. Since there are 256 possible combinations of eight pins, you need a numbering system that allows you to use a single number to specify which of the 256 possible patterns you want. By labelling each pin with its own number, you can use a numbering system that allows you to specify exactly which pins should be fired.

To fire any one pin, you send its number, according to the numbering system shown in the figure on the next page. To fire more than one pin at

the same time, add up the numbers of the pins and send the sum to the printer. Therefore, with these labels for the pins, you fire the top pin by sending 128. To fire the bottom pin, you send 1. If you want to fire only the top and bottom pins, you simply add 128 and 1, and send 129.

By adding the appropriate label numbers together, you can fire any combination of pins. The figure below shows three examples of how to calculate the number that fires a particular pattern of pins.

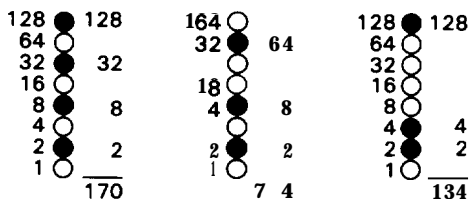

With this numbering system, any combination of the eight pins adds up to a decimal number between 0 and 255, and no numbers are duplicated. Before you can put these numbers in a graphics program, however, you need to know the format for graphics commands.

## Graphics commands

Graphics commands are quite different from most other commands. For most of the other modes, such as emphasized and double-wide, one command turns the mode on and another turns it off. For graphics, the command is more complicated because the command that turns on a graphics mode also specifies how many columns of graphics will be printed. After the printer receives this command, it interprets the next numbers as pin patterns and prints them on the paper.

The graphics command format

There are several different graphics commands giving different horizontal dot densities and printing speeds. Because the format is almost the same for all the commands, however, the example here keeps things simple by using only the single-density graphics command, ESC K. In single-density graphics, there are 60 dots per inch horizontally.

The command to enter single-density graphics mode is ESC K n1 n2. In BASIC the command is given in this format:

```
LPRINT CHR$(27);"K";CHR$(n1);CHR$(n2);
```

In this command, ESC K selects single-density graphics, and n1 and n2 specify the number of columns to reserve for graphics.

### Column reservation numbers

The graphics command requires more than one number to specify how many columns to reserve because although one line can use thousands of columns, the FX does not use numbers larger than 255 (decimal). Therefore, the graphics mode command uses two numbers for reserving columns.

To figure n1 and n2, divide the total number of columns by 256. The result is n2; the remainder is n1. Since the command is set up for two numbers, you must supply two numbers even if you need only one. When you need fewer than 256 columns, just make n1 the number of columns you are reserving and make n2 a zero.

For example, if you wish to send 1632 columns of graphics data, n1 should be 96 and n2 should be 6 because  $1632 = 96 + (6 \times 256)$ .

### Graphics data

After receiving a graphics command such as ESC K n1 n2, the printer prints the number of codes specified by n1 and n2 as graphics data, no matter what codes they are. This means that you must be sure to supply exactly the right amount of graphics data. If you supply too little, the printer stops and waits for more data and seems to be locked. The next data sent will then be printed as graphics, even if it is really text. On the other hand, if you supply too much graphics data, the excess will be printed as regular text.

### Graphics programming

Here is an example that shows how a graphics command, column reservation numbers, and data can be used to print a single line of graphics. The example is a BASIC program. You can, of course, use another programming language. The principles are the same.

The first line of the program specifies single-density graphics for 40 columns:

```
100LPRINTCHR$(27);"K";CHR$(40);CHR$(0);
```

The second line is the data that is printed as pin patterns. It uses the number 74 to produce one of the patterns shown above. The FOR-NEXT loop sends 40 columns of data.

Here is the second line of data:

```
200 FOR X=1 TO 40:LPRINT CHR$(74);: NEXT X
```

That is the whole program. In BASIC, semicolons at the ends of the lines are very important; they prevent the computer from sending other codes after the ones you specify. In other languages you may have to use a special command to send a single code at a time. Run the program to see the result below. Although it is not as interesting as the examples at the beginning of this chapter, it shows exactly how the graphics mode works.



## WIDTH statements

Some software programs (including most versions of BASIC) automatically insert carriage return and line feed codes after every 80 or 130 characters. This is usually no problem with text, but can spoil your graphics. Two extra columns of graphics are printed in the middle of the ones you send, and two data numbers are left over and printed as text.

In some versions of BASIC you can prevent unwanted control codes in graphics by putting a WIDTH statement at the beginning of all graphics programs. The format in many forms of BASIC is either WIDTH "LPT1:", 255 or WIDTH LPRINT 255. Check your software manual for the proper format.

## Printing taller patterns

The next example shows how several lines of graphics can be formed into a figure taller than eight dots. It uses programming techniques for producing textured or repetitive patterns.

The program is listed below. The lines inside each pair of FOR and NEXT statements have been indented so that you can see how the program works; the spaces are not needed for the program to run.

```
100 WIDTH "LPT1:", 255
110 LPRINT CHR$(27);"A";CHR$(8);
120 FOR R = 1 TO 6
130 LPRINT CHR$(27);"K";CHR$(100);CHR$(0);
140   FOR X = 1 to 50
150     LPRINTCHR$(170);CHR$(85);
160   NEXT X: LPRINT
170 NEXT R
180 LPRINT CHR$(27);"@"
```

If you run the program, you will see how it combines six print lines into a pattern.

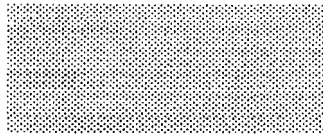

There are five basic steps that the program goes through to produce this kind of pattern.

1. The computer is prevented from adding any extra characters by the WIDTH statement (line 100).
2. The line spacing is changed to 8/72 of an inch—the height of the dot patterns used in the program (line 110).
3. The program goes through the graphics commands the required number of times (lines 120 and 170).
4. A new graphics command is used for each line printed (lines 130-160). This part of the program is similar to the last example, but two columns are printed each time through the loop making a total of 100.

5. The last important thing to do is to reset the printer to its default settings, including the normal line spacing (line 180).

Notice that the graphics command (ESC K) can be in effect for only one print line. To print more than one line of graphics, the graphics command must be issued before each line.

## Density varieties

Although all the examples so far in this section have been in the single-density graphics mode, there are seven other eight-pin densities and two that use all nine pins.

Nine-pin graphics is not necessary for most uses, but you can find the command (ESC ^) in the Command Summary in Chapter 8. The four most common eight-pin modes are ESC K, ESC L, ESC Y, and ESC Z. There is also a general purpose command for any of the eight-pin graphics modes: ESC \*. This command is used in the same way as the individual commands, except that before n1 and n2 you must send the code for the graphics mode required.

The different graphics modes are summarized in the following table:

Option	Alternate Code	<i>m</i>	Horiz. density (dots/in.)
Single-density	ESC K	0	60
Double-density	ESC I	1	<b>120</b>
High-speed double-density*	ESC Y	2	120
Quadruple-density*	ESC Z	3	240
CRT I	none	4	80
Plotter (1:1)	none	5	<b>72</b>
CRT II	none	6	90
Double-density plotter	none	7	144

\*Adjacent dots cannot be printed in this mode.

Modes 4, 5, 6, and 7 are special modes that alter the horizontal density to give the proportions of a computer monitor (the CRT modes) or to match the vertical density so as to give round circles (the plotter mode).

In two modes, high-speed double-density and quadruple-density, the print head cannot print two consecutive dots with the same pin, so it

prints dots in only half the possible dot positions in any one row. The higher density means that the resolution of the pattern is better than in single-density mode. When you design patterns in these two modes, however, you must make sure that no dots overlap.

### Reassigning a graphics mode

Another graphics command lets you assign a different eight-pin graphics mode to one of the specific eight-pin graphics commands. You can use this command with graphics software programs to quickly change the density and proportions of your printouts. Changing the graphics option changes the width without changing the height.

The command for reassigning a graphics mode is ESC ? c m. In this command, c is a letter designating one of the four alternate graphics codes (K, L, Y, or Z) and m is the mode number of the new mode, as listed in the table on page 4-15.

For example, to change the ESC K command to select the CRT I screen graphics mode, the command in BASIC is' the following:

```
LPRINTCHR$(27);"?K";CHR$(4);
```

A little experimentation should tell you whether the reassigning command can improve your graphics printouts.

### Designing your own graphics

This section takes you through the development of a graphics program. The example is not especially complicated, but it does include the same steps you would use for a more complex figure.

You should plan your figure with dots on graph paper, but before beginning to place the dots, you must decide which graphics density you want. The figure on the next page shows the differences between three common modes.

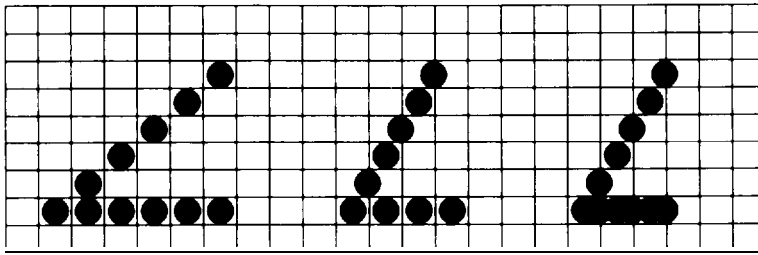

Single

High-speed  
double

Double

In this figure you can see the main rules for graphic design in the three densities:

- In single-density no dots can be placed on vertical lines.
- In high-speed double-density, dots can be placed on vertical lines, but no dots can overlap.
- In double-density, dots can be placed on vertical lines, and they can overlap.

Now look at the high-speed double-density design below. It should point you in the right direction for your own work.

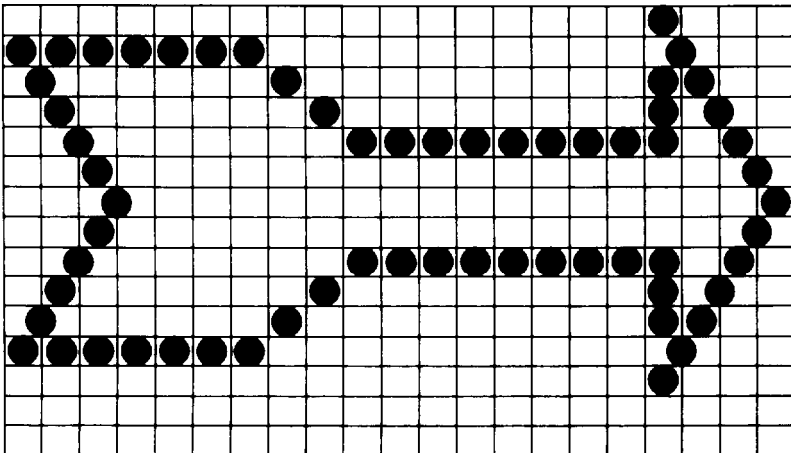



```

100 WIDTH "LPT1:", 255
110 LPRINTCHR$(27);"A";CHR$(7);
120 FOR ROW = 1 TO 2
130 LPRINT CHR$(27);"Y";CHR$(41);CHR$(0);
140   FOR COLUMN = 1 TO 41
150     READ N
160     LPRINT CHR$(N);
170   NEXT COLUMN
180 LPRINT
190 NEXT ROW
200 END
210 DATA 64,32,80,8,68,2,64,0,64,0
220 DATA 64,0,64,0,32,0,16,0,8,0
230 DATA 8,0,8,0,8,0,8,0,8,0,8,0
240 DATA 184,64,32,16,8,4,2
250 DATA 8,16,40,64,136,0,8,0,8,0
260 DATA 8,0,8,0,16,0,32,0,64,0,64,0
270 DATA 64,0,64,0,64,0,64,0,64,0,64,0
280 DATA 116,8,16,32,64,128,0

```

When you run the program, it produces this printout:



If you want to see the figure in other densities, change the Y in line 130 to L or Z.

## User-Defined Characters

The FX has several hundred different characters stored in its ROM (Read Only Memory). Although this number includes draft, italic, international, Epson Extended Graphics, and NLQ (near letter quality) characters, sometimes you may want to have a few more. For those occasions when you need a special character or a few letters in a different typeface, the FX allows you to create your own characters and print them just as if they were ordinary letters.

You can make the task of defining characters easier by using a commercial software program that either assists you in creating

characters or simply supplies you with sets of characters already created. Also, some popular commercial software programs take advantage of the printer's user-defined character function to enhance printouts. These characters are sometimes called download characters.

## Defining your own characters

The printout below displays a few such characters to give you an idea of what can be done, but remember that since these characters are truly user-defined, you can create whatever you need or want.



DIP switch 1-1 must be off before you can create a user-defined character. The procedure for designing a character is a simple three-step process:

1. Plan your character.
2. Run a program to test your work and calculate the required DATA numbers.
3. Run another program to put the character in your printer's memory for use whenever you need it.

Once you define a character, you can print it in either draft or NLQ. If you print it in NLQ, the printer adds dots to make the character more fully formed.

After you have created your own characters with these programs, certain keys that you seldom use generate the user-defined characters. For example, you can press the ( key to print **Ⓟ** .

You can create any type of character. The only restriction is that the characters you define must follow the same rules that govern the rest of the characters printed by the FX. They must fit into an 11 x 9 matrix, no dot can overlap another (in draft mode), and either the top or the bottom row must be empty.

Suppose you want to print the scientific symbol for the planet Mercury. Although the FX has a number of special symbols, that is not one of them. First, use a grid like the one below to plan where to place the dots.

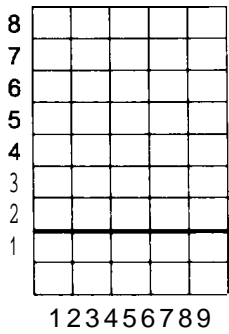

Because the last two columns are reserved for the space between characters, they are not included in the grid. And since most characters do not use the bottom two rows, there is a heavy line to indicate the usual lower limit for an FX character.

When you place your dots on this grid, remember that dots cannot go on horizontal lines, but they can go on vertical lines. If they overlap other dots, they will not be printed in draft, only in NLQ. As you design your characters, draw the dots as large as the circles you see in the example below. (The printer prints dots, but it is best to use circles when planning your characters.)

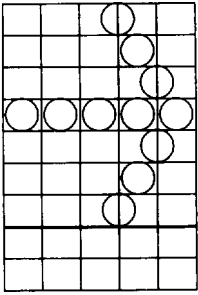

## First definition program

The next few sections explain the steps used to create the symbol for Mercury. The figure below shows the grid used to design the character.

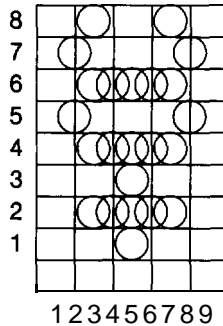

Once you have drawn your dots on the grid, type the following BASIC program.

```
100 DIM F(9)
110 FOR I=1 TO 9
120 PRINT "WHICH ROWS HAVE DOTS IN COLUMN";I
130 INPUT R: IF R=0 THEN 150
140 F(I)=F(I)+2^(R-1)
150 IF R=0 THEN NEXT I ELSE GOTO 130
160 LPRINT CHR$(27)":"CHR$(0)CHR$(0)CHR$(0);
170 LPRINT CHR$(27)%"CHR$(1)CHR$(0);
180 LPRINT CHR$(27)"&"CHR$(0)CHR$(60)CHR$(60);
190 LPRINT CHR$(128);
200 LPRINT CHR$(27)"x0";
210 FOR X=1 TO 9
220 LPRINT CHR$(F(X));:NEXT X
230 LPRINT CHR$(0)CHR$(0);
240 LPRINT "YOUR CHARACTER IN 10 CPI: <<<"
250 LPRINT "IN DOUBLE-WIDE EMPHASIZED 10 CPI: ";
260 LPRINT CHR$(27)"!*<<<"
270 LPRINT CHR$(27)"!CHR$(0)"INNLQ: ";
280 LPRINT CHR$(27)"x1<<<"
290 LPRINT CHR$(27)"!CHR$(0)"YOUR DATA NUMBERS:"
300 FOR K=1 TO 9: LPRINT F(K);: NEXT K
310 LPRINT: END
```

## Running the program

Now run the program. For each of the nine columns, the program asks for the numbers of the rows in which you want dots to appear. Enter the row numbers one at a time, pressing the **Enter** key after each one. When you have entered all the numbers for a column or when you want no dots in a column, press **Enter** without a number. Remember that the vertical lines in the grid are the even-numbered columns.

To see the program produce the Mercury symbol, run the program and follow these instructions:

1. When the screen message asks what rows have dots in column 1, press **Enter** to indicate that no dots go in that column.
2. For column 2 (the vertical line) press 7, **Enter**, 5, and **Enter** again to indicate that you want dots in rows 7 and 5. Then press **Enter** alone to indicate that no more dots go in column 2.
3. For column 3 press 8, 6, 4, and 2, and **Enter** after each of them. Press **Enter** to finish with column 3 and go on to column 4. (The rest of the directions assume that you know to press **Enter** after each number and one extra time to end the entries for each column.)
4. For column 4 enter 6, 4, and 2.
5. For column 5 enter 6, 4, 3, 2, and 1 .
6. For column 6 enter 6, 4, and 2.
7. For column 7 enter 8, 6, 4, and 2.
8. For column 8 enter 7 and 5.
9. For column 9 press **Enter** only.

Now wait a moment for your computer to calculate the dot patterns and your printer to print the new character in two different typesyles and

NLQ. Your printout also gives you nine numbers, which you use in the next program. You should get the printout you see below:

```
YOUR CHARACTER IN 10 CPI: $ $ $  
IN DOUBLE-WIDE EMPHASIZED 10 CPI: ≡ ≡ ≡  
IN NLQ: ₪ ₪ ₪  
YOUR DATA NUMBERS:  
0 80 170 42 47 42 170 80 0
```

When you get to this point with a character of your own, you see how it looks. If you want to make any changes, move the dots as needed and rerun the program.

If you want to put dots in the bottom row, change the number in line 190 from 128 to 0. Then the usable rows are those shown in the figure below.

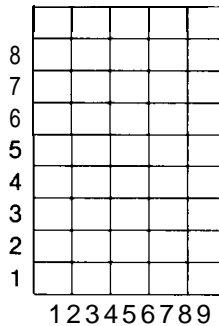

### Second definition program

Once the character looks the way you want it to, you can enter, modify, and run the next program. The program listed here creates the Mercury character, but you can use it for any characters you create if you make one or two changes, as explained after the program listing.

```

90 FOR P=58 TO 63: LPRINT CHR$(P);" ";: NEXT P
95 LPRINT
100 K=1: IF K>3 THEN A=58 ELSE A=60
110 LPRINT CHR$(27)":"CHR$(0)CHR$(0)CHR$(0);
120 LPRINT CHR$(27)%"CHR$(1)CHR$(0);
130 LPRINT CHR$(27)%"&"CHR$(0)CHR$(A)CHR$(A-1+K);
140 FOR Z=1 TO K
150 LPRINT CHR$(128);
160 FOR X=1 TO 9
170 READ R
180 LPRINT CHR$(R);: NEXT X
190 LPRINT CHR$(0)CHR$(0);
200 NEXT Z
210 DATA 0,80,170,0,47,0,170,80,0
290 FOR P=58 TO 63: LPRINT CHR$(P);" ";: NEXT P

```

To use this program for your own character or characters, change the DATA numbers in line 210 by substituting the numbers generated by the first program when you created your own character. If you have created more than one character, put the DATA numbers for each character on a separate line as you see in the example below:

```

210 DATA 112,8,0,138,116,138,0,8,112
220 DATA 56,68,146,40,130,40,130,68,56

```

Check your work by making sure that there are nine numbers in each line and that the numbers are separated by commas. Also make the change in line 100 explained below.

This program is designed for defining up to 6 characters. Line 100 states  $K=1$ , but to define more than one character, use the total number of characters you are defining instead of the 1 in that line. You can actually define as many as 256 characters, but if you define more than six characters, you have to change a few lines in the program.

## Running the program

When you run this second program, it prints six characters, then re-defines some or all of them and prints them again, as in the example below.

```
⋮ ; < = > ?  
: ; ψ ⊗ ⚡ ?
```

When printed by your own program, these two lines provide you with a key to the characters your FX can now print. When you press the key for one of the characters in the top row, the printer prints the corresponding character in the bottom row. In the example above, if you type < your FX prints ⚡ (although your screen continues to show the character < ).

If you have designed a few characters and want to use them with your word processing program, for example, just run the second definition program before you start using your word processing program. Then use the two-line printout as your guide to tell you which keys to press for your new characters.

## Chapter 5

# Maintenance

Cleaning the Printer .....	5-2
Replacing the Ribbon .....	5-3
Transporting the Printer .....	5-6

## Cleaning the Printer

To keep your printer operating at its best, you should clean it thoroughly several times a year.

Follow these steps to clean the printer:

1. Turn off the printer.
2. Remove the paper guide, tractor unit, and any installed options.
3. Use a soft brush to carefully clear away all dust and dirt.

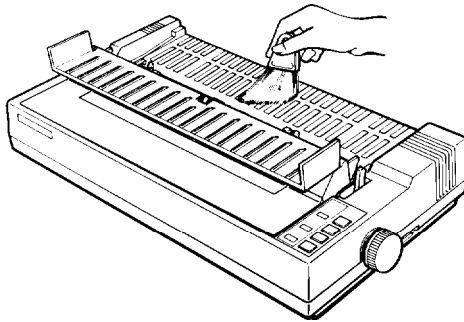

4. If the outer case or paper guide is dirty or dusty, clean it with a soft, clean cloth dampened with mild detergent dissolved in water. Keep the printer cover in place to prevent water from getting inside the printer.

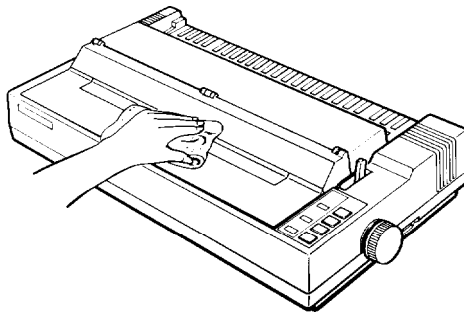



## WARNING:

- Never use alcohols or thinners to clean the printer; these chemicals can damage the components as well as the case.
- Be careful not to get water on the printer mechanism or electronic components.
- Do not use a hard or abrasive brush.
- Do not spray the inside of the printer with lubricants; unsuitable oils can damage the mechanism. Contact your Epson dealer if you think lubrication is needed.

## Replacing the Ribbon

When your printing becomes too faint you need to replace the ribbon. Use only the following Epson replacement ribbon cartridges: the #8750 ribbon cartridge for the FX-850 or the #8755 ribbon cartridge for the FX-1050.

To replace the ribbon follow the procedure below:

1. Turn off the power to the printer and remove the printer cover.



WARNING: If the printer has been used recently, the print head may be hot. Let it cool before attempting to replace the ribbon.

2. Remove the old ribbon cartridge by grasping the black fin-like handles (two on the FX-1050, and one on the FX-850) and lifting the cartridge straight up and out of the printer.

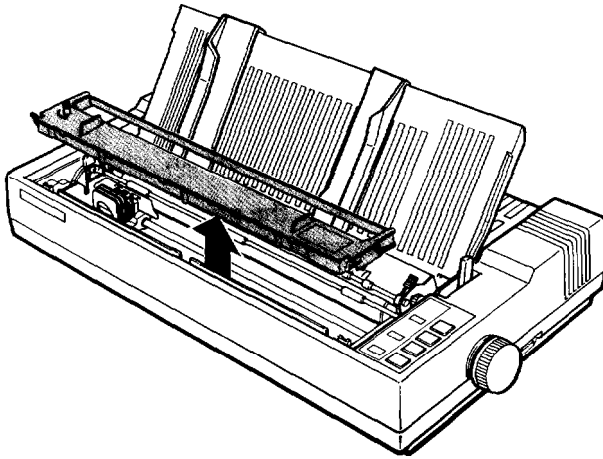

3. Slide the print head to the middle of the printer.

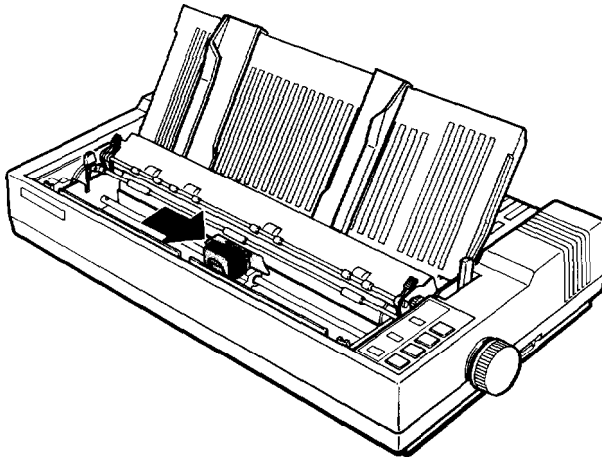

4. Unwrap the new ribbon, and turn the ribbon-tightening knob in the direction of the arrow to remove excess slack.

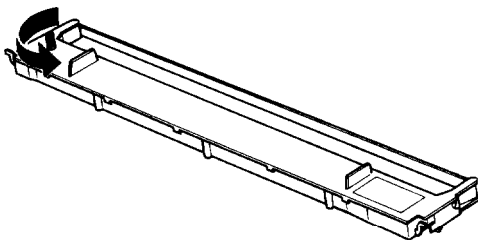

5. Hold the new ribbon cartridge by the fin-like handle(s), and firmly insert it into place, making sure that the plastic hooks fit into the slots as shown below.

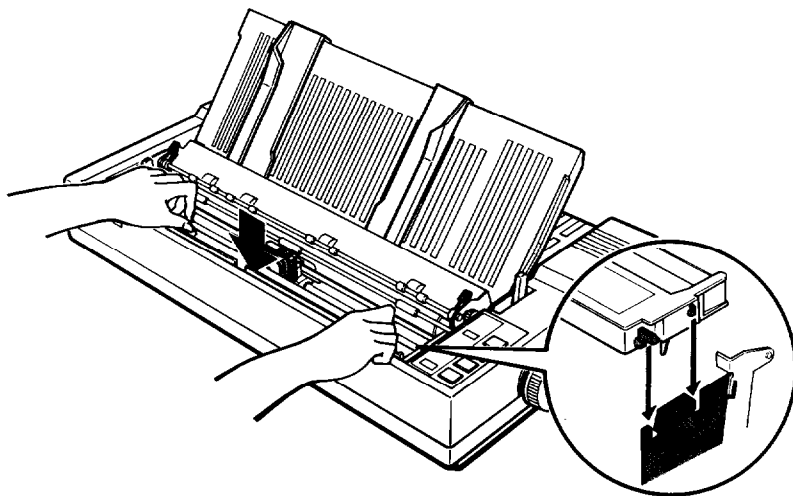

6. Use a pointed object, such as the tip of a pencil, to guide the ribbon between the print head and ribbon guide. At the same time, turn the ribbon-tightening knob in the direction of the arrow to help guide the ribbon into place.

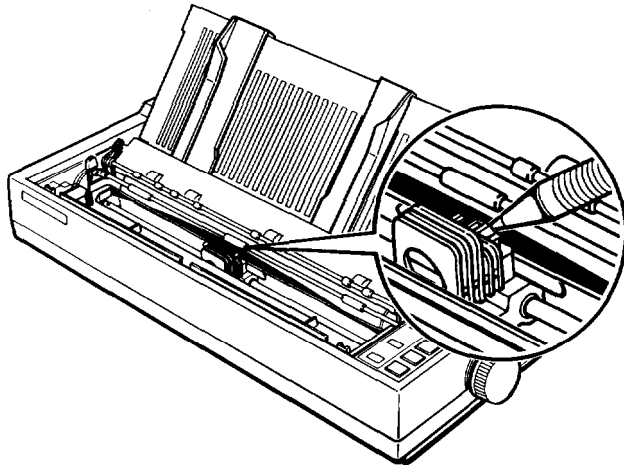

7. Check to make sure that the ribbon is not twisted or creased. You can check the installation by sliding the print head from side to side along the carriage.
8. Reattach the printer cover.

## Transporting the Printer

If you need to transport your printer some distance, carefully repack the printer using the original box and packing materials, as described below.

1. Turn off the printer.
2. Remove the paper guide, paper rest, and cut sheet feeder, if installed.
3. Unplug the power cable from the electrical outlet; then disconnect the cable between the printer and the computer.

4. Remove the ribbon cartridge and platen knob.

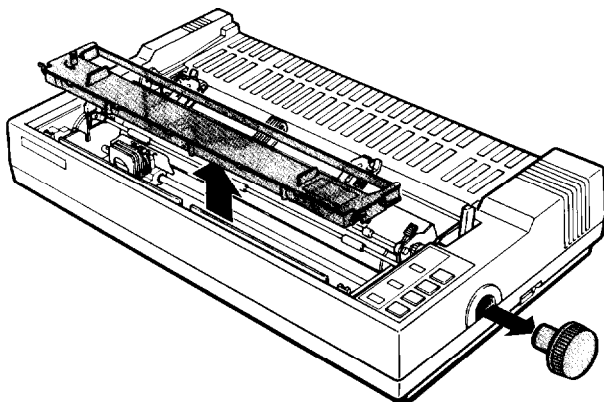

5. Slide the print head to the middle of the printer. Then, using a cross-head screw driver, reattach the two transport locking brackets.

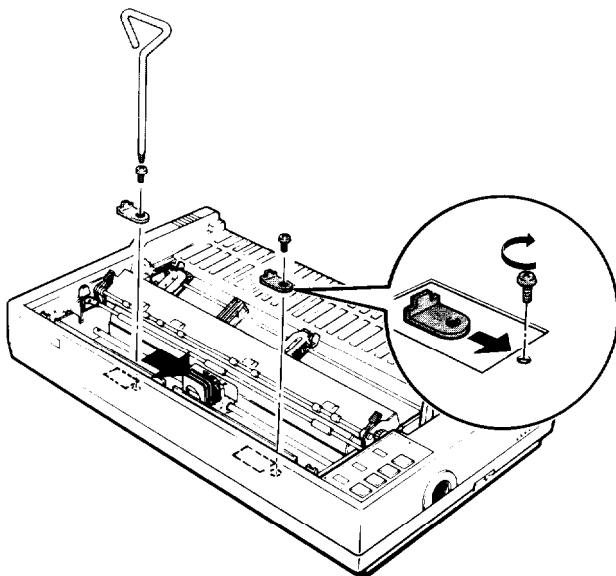

6. Attach the left and right locking tabs.

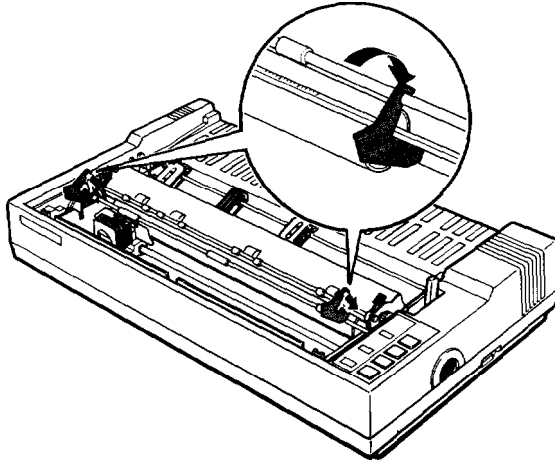

7. Slide the head all the way to the left, and insert the print head protector between the paper bail and platen as shown below.

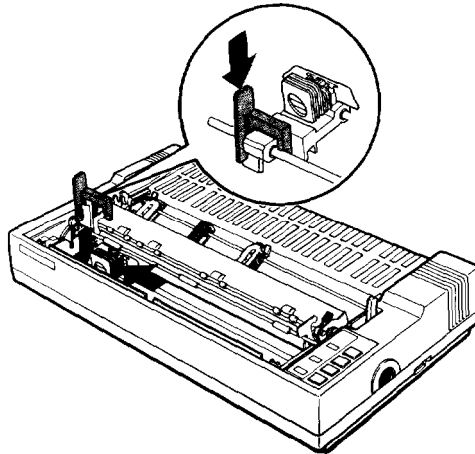

8. Attach the printer cover.

After replacing the packing material, put the printer in its box and prepare it for transportation.

# Troubleshooting

Problems and Solutions .....	6-2
The printer does not print .....	6-2
The printer stops printing .....	6-2
The printout is spaced incorrectly .....	6-3
The print out is faint or uneven .....	6-3
The printout is not what you expect .....	6-3
Single sheets do not feed properly .....	6-4
Continuous paper does not feed properly .....	6-4
Cut sheet feeder does not load paper correctly .....	6-5
Data Dump Mode .....	6-5

# Troubleshooting

This chapter discusses problems you may encounter and their likely solutions. At the back of the chapter is a section on the data dump mode. This mode helps more experienced users determine the causes of communication problems between the printer and the computer.

## Problems and Solutions

This section lists possible problems and their likely solutions.

### The printer does not print

- Be sure the printer is turned on and the **POWER** light is on. If the printer is turned on but the **POWER** light is not on, check to see that the printer is fully plugged in and that the electrical outlet is also turned on.
- Be sure the **ON LINE** light is on. If it is not on, press the **ON LINE** button.
- Be sure the printer is connected securely to the computer. Check both ends of the cable between the printer and the computer.
- Be sure the printer is not out of paper. (The **PAPER OUT** light should be off.)

If the printer still does not print, disconnect the printer from the computer and try the self test described in Chapter 1. If the self test works properly, the printer is working and the problem probably lies in the computer, the software, or the cable. If the self test does not work, contact your Epson dealer.

### The printer stops printing

- The printer may be out of paper. Check the paper supply.
- The paper may be jammed. Remove the jammed paper and reload.
- The ribbon may be jammed. See the section on replacing the ribbon in Chapter 5.

- If the printer stops and the beeper sounds, turn the printer off and then turn it back on and try to print again. If the printer beeps again and does not print, take it to a qualified service person.

### **The printout is spaced incorrectly**

- If all the text is printed on the same line, no line feed command is being sent at the end of each line of text. Turn DIP switch 2-4 on.
- If the printer is inserting extra blank lines between lines of text, extra line feed commands are being sent. Turn DIP switch 2-4 off.
- If the printer inserts extra blank lines even after turning DIP switch 2-4 off, disable the AUTO FEED XT signal of your interface.

### **The printout is faint or uneven**

- The ribbon may not be properly installed. See the section on ribbon installation in Chapter 1 .
- The ribbon may be worn out. See the section on replacing the ribbon in Chapter 5.
- The paper thickness lever may be in the wrong position. See the section on the paper thickness lever in Chapter 2.
- The print head may be worn out. This is especially likely if parts of printed characters are missing. Contact your dealer to have the head replaced. Never attempt to replace the head yourself because other parts of the printer should be checked at the same time.

### **The printout is not what you expect**

- The wrong international character set may be selected. See the section on international character sets in Chapter 3.
- The wrong character table (italics or Epson Extended Graphics) may be selected. See the section on character tables in Chapter 3 and in Appendix B.
- The printer may not be securely connected to the computer. Check both ends of the cable between the printer and the computer.

- If you cannot define userdefined characters, make sure that DIP switch I-1 is off.
- Your software's font, size, or page layout settings may not be selected properly. See that your software is correctly set up for your printer.
- Your application program may be changing the SelecType settings. Use the program's setup procedure to remove codes that interfere with SelecType, or use the printer control codes for your application program instead of SelecType. (See your software manual.)

### **Single sheets do not feed properly**

- The position of the paper release lever may be wrong. Push it back to the single sheet position.
- The paper may be too large or too small. See the paper specifications in Appendix A.
- The paper guide may not be installed properly. See the section on installing the paper guide in Chapter 1 and on using single sheets in Chapter 2.
- The cut sheet feeder mode may be selected by the DIP switch. See the section on setting DIP switches in Chapter 3.

### **Continuous paper does not feed properly**

- The position of the paper release lever may be wrong. Pull it forward to the continuous paper position.
- The paper may not be mounted on the sprockets correctly. See that the sprocket holes of the paper fit correctly over the sprockets.
- The paper guide may not be installed properly. See the section on continuous paper in Chapter 2.
- The paper supply may be stacked too far from the printer or not aligned with the tractor. Also, there may be some obstacle in the way of the paper or something on top of the paper supply. See Chapter 2 for instructions on the proper placement of the paper supply.

## Cut sheet feeder does not load paper correctly

- The cut sheet feeder mode may not have been selected with the DIP switch.
- The position of the paper release lever may be wrong. Push the paper release lever back to the single sheet position.
- The cut sheet feeder may not be installed properly.
- The paper supply may not be loaded properly.
- The paper may not be the type required for proper operation of the cut sheet feeder.
- The paper set lever of the cut sheet feeder may not be pushed back.
- The paper length may not be set correctly.
- More than 150 sheets may be loaded. Remove the extra sheets.

See the section on the cut sheet feeder in Chapter 7 for more information on cut sheet feeder problems.

## Data Dump Mode

The printer has a special feature to make it easy for experienced users to find the cause of communication problems between the printer and application programs. In data dump mode, an exact printout of the codes reaching the printer is produced.

1. To enter the data dump mode, hold down the FORM FEED and LINE FEED buttons at the same time while you turn on the printer.
2. Next, run either an application program or one you have written in any programming language. Your printer prints all the codes sent to the printer in hexadecimal format as shown below:

```
1B 40 1B 52 00 1B 74 01 ( 36 12 1B 50 1B 70 00 .@.R..t..6..P.p.  
20 20 54 68 69 73 20 6C ( 20 61 6E 20 65 78 61 This is an exa  
6D 70 6C 65 20 6F 66 2C ( 20 64 61 74 61 20 64 mple of a data d  
75 6D 70 20 70 72 69 6E ( F 75 74 2E 20 54 68 ump printout. Th  
69 73 20 66 65 61 74 75 ) 5 20 6D 61 6B 65 73 is feature makes  
0A 20 20 20 20 20 69 74 ) S 61 73 79 20 66 6F it easy fo
```

3. To turn off the data dump mode, press the **ON LINE** button to take the printer off line, and then turn off the printer. (The data dump mode can also be cancelled by sending an **INIT** signal from the computer.)

Look at the data dump shown in Step 2. By comparing the characters printed in the right column with the printout of the hexadecimal codes, you can check what codes are being sent to the printer. If characters are printable, they appear as their true ASCII characters. Nonprintable codes, such as control codes, are represented by dots.

As an example of how to interpret a data dump printout, look at the first three hex codes on the second line of the printout sample (20 20 54). Each hex 20 represents a space, while hex 54 represents the letter T. Check the second line of the right column and you will find the letter T preceded by two spaces.

The chart below interprets the first line of codes:

Hex codes	Command	Function
1B 40	ESC @	Initialize printer
1B 52 00	ESC R0	Select USA character set
1B 74 01	ESC t1	Select Epson Extended Graphics
1B 36	ESC 6	Printable code expansion
12	DC2	Cancel condensed mode
1B 50	ESC P	Select 10 cpi
1B 70 00	ESC p0	Cancel proportional

## Using Printer Options

The Cut Sheet Feeder .....	7-2
Installation .....	7-2
Setting the sheet feeder mode .....	7-4
Recommended paper .....	7-5
Paper loading .....	7-5
Envelope loading .....	7-8
Using the cut sheet feeder .....	7-8
Software operation .....	7-9
Setting up your software .....	7-9
Control panel operation .....	7-11
Testing the printer in the cut sheet feeder mode .....	7-11
Switching from the cut sheet feeder to continuous paper .....	7-12
Single sheet insertion .....	7-14
The Pull Tractor .....	7-15
Installation and use .....	7-15
When you are finished printing .....	7-21
Using the pull tractor alone .....	7-21
Removing the pull tractor .....	7-21
Interface Boards .....	7-22
Choosing an interface .....	7-22
Compatible interfaces .....	7-23
Removing the upper case .....	7-23
Installing the board .....	7-28
Attaching the upper case .....	7-31

## The Cut Sheet Feeder

The optional cut sheet feeder #7339 (for the FX-850) or #7340 (for the FX-1050) gives you easier and more efficient handling of single sheet paper. Up to 150 sheets of standard bond paper can be fed automatically into the printer without reloading. The cut sheet feeder can also automatically feed envelopes.

### Installation

Attach the assembled cut sheet feeder as follows.

1. Turn off the printer.
2. Remove the printer cover and the paper guide.
3. Make sure the paper release lever is pushed back to the single sheet paper position.

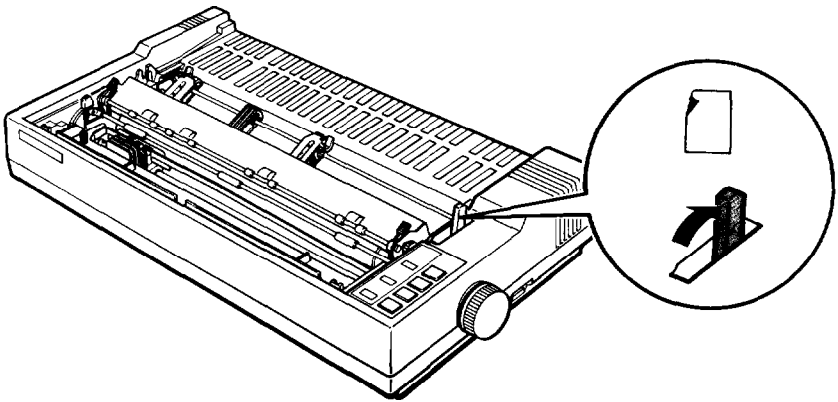

4. Remove the paper tension unit by pressing open the release levers and, at the same time, lifting up on the front of the unit.

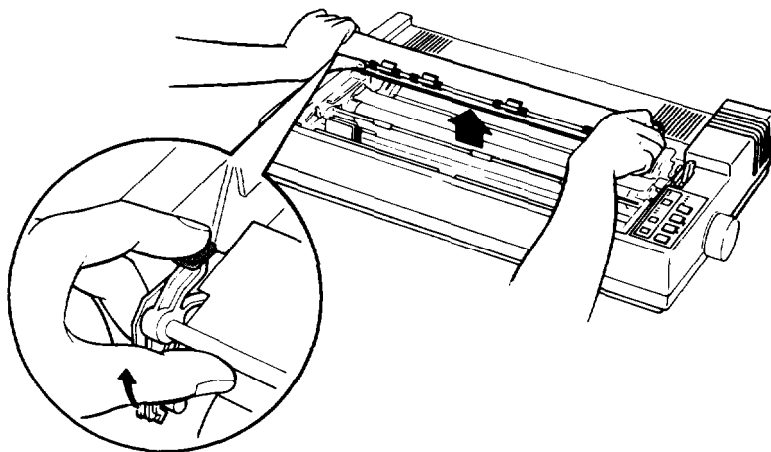

5. Tilt the feeder forward slightly to fit the notches at the base of the unit over the pins on the printer; then tilt the unit back until it rests on top of the printer.

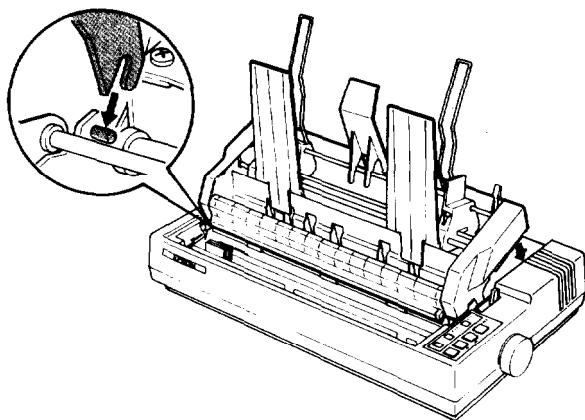

6. Detach the front section of the printer cover.

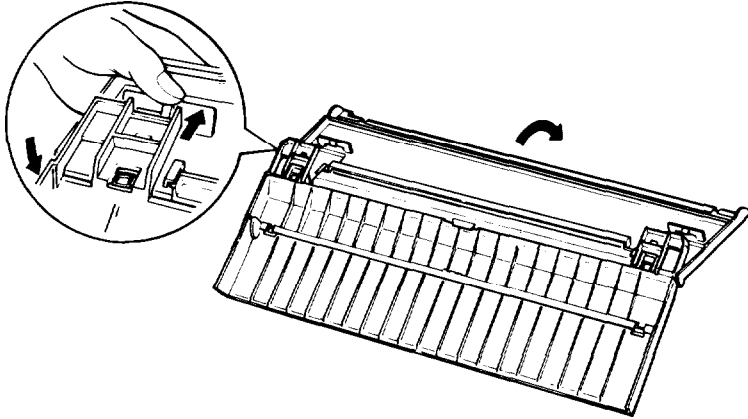

7. After raising the cut sheet feeder's paper path guide, attach the front cover to the printer. Then close the paper path guide.

### Setting the sheet feeder mode

To allow your printer to use the cut sheet feeder you need to set DIP switch 2-2 to on. If you need more information on how to do this, see the section on setting DIP switches in Chapter 3. To set the cut sheet feeder mode, do the following:

- Turn the printer off.
- Set DIP switch 2-2 to the on position using a pointed object, such as the tip of a pencil.
- Turn the printer back on.

Always change DIP switch settings with the printer power turned off. The printer checks and recognizes new settings only at the time the power is turned on.

## Recommended paper

**Paper:** For best results, use typewriter-quality paper. If you use paper with a glossy or textured surface, you should test it before regular use. The cut sheet feeder can hold up to 150 sheets of paper. Do not use multiple-part forms or labels.

**Envelopes:** You can print on air mail, plain, or bond envelopes. The cut sheet feeder can hold up to 25 plain or bond envelopes, or 30 air mail envelopes. Before printing on envelopes, you need to set the paper thickness lever. See the section on printing on special paper in Chapter 2.



**WARNING:** Printing past the edge of envelopes or heavy paper can damage the print head. Be absolutely sure that the printing is no closer than 1/4 of an inch to the edges.

## Paper loading

To load paper, follow the steps below.

1. Pull the paper set lever all the way forward until the paper supports retract and lock open to allow for paper loading. Make sure that the two small front levers are up when using normal paper.

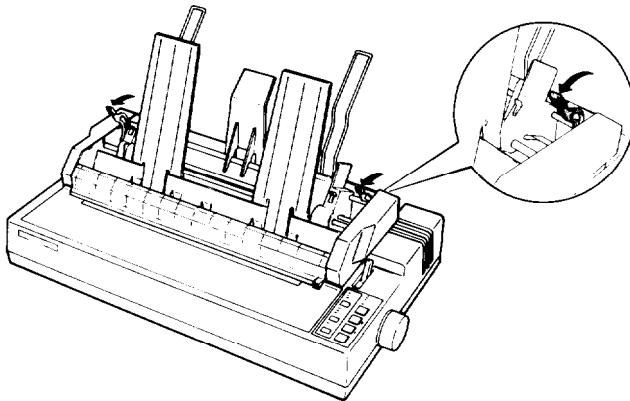

Slide the left paper guide all the way to the left and slide the right paper guide to roughly match the width of your paper.

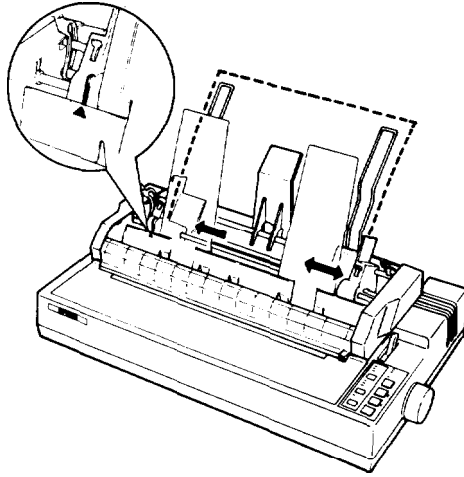

3. Take a stack of paper and fan it as shown. This keeps the sheets from sticking to one another. Tap the side and bottom of the paper on a flat surface to even up the stack.

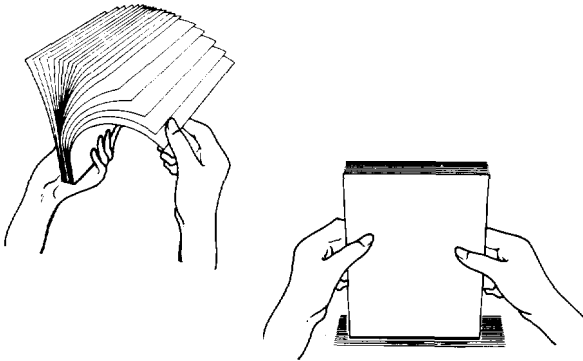

4. Insert the paper between the paper guides, aligning it with the left edge of the guide. Then adjust the right paper guide until the paper is held firmly (but not so tightly that it causes the paper to bunch).

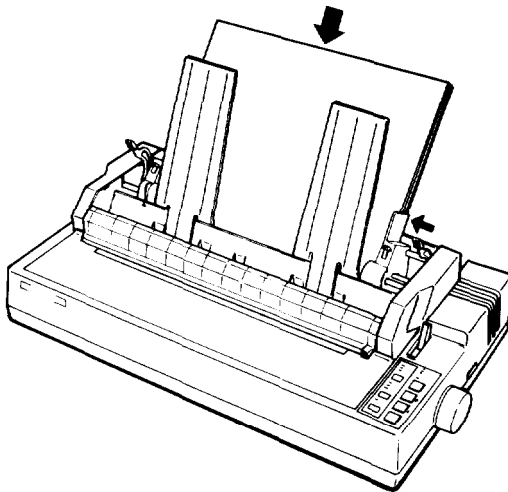

5. Push the paper set lever back to clamp the paper against the guide rollers. The lever will not close completely if you use too much paper. If the lever does not close, remove some paper from the stack and try again.

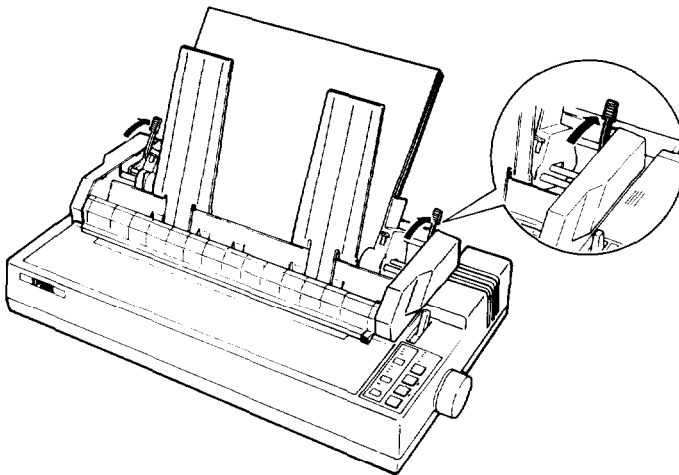

## Envelope loading

Envelopes are loaded in much the same way as regular paper. To load envelopes, you need to do the following:

1. Set the paper thickness lever to match the thickness of your envelopes. (For specific information on paper thickness settings, see the section on printing with special paper in Chapter 2.)
2. Follow steps 1 through 5 of the previous section on paper loading to load envelopes. You can load up to 25 plain or bond envelopes, or 30 air mail envelopes.
3. Push down on the two front levers until they lock into position.

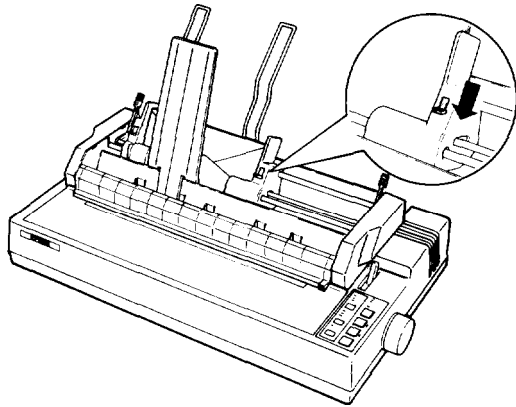

## Using the cut sheet feeder

After loading paper into the cut sheet feeder, make sure the **ON LINE** light is on. Once the printer is in the sheet feeder mode, a new sheet of paper loads automatically whenever a printable character or line feed command is sent to the printer.

When the cut sheet feeder runs out of paper, it stops paper feeding and the **PAPER OUT** light comes on. To start printing again, load more paper

sand then press the **ON LINE** button. The printer starts printing from the point at which it was stopped.

If you turn your printer off during the time the printer detects a paper out or paper jam condition, any data remaining in the printer's buffer is discarded.

## Software operation

This command causes the printer to eject the sheet in the printer without loading the next sheet:

FF            form feed

The sheet in the printer is automatically ejected and the next sheet is loaded if the paper reaches the bottom of the print area when any of the following line feed commands is used:

LF            line feed; advances the paper by one line

VT            vertical tab; advances the paper to the next vertical tab position

ESC J        performs line feed in units of 1/216 of an inch.

## Setting up your software

When you switch between continuous paper and cut sheet feeder paper you usually need to change the settings of your software program. Because of the physical requirements of **feeding** a single sheet of paper, sheet feeders create a top and bottom margin on each sheet. To work properly, your software program needs to know how many printable lines are available on the page.

Paper comes in many different sizes and it is sometimes difficult to know exactly how many printable lines per page you have. When you perform a self test in sheet feeder mode, the printer automatically counts and prints the number of lines that are available on any size of paper. This is the number of lines you should use as the page length in your software setup. See the following section on the self test in cut sheet feeder mode for more details.

In addition to the number of printable lines, which your software may refer to as page length or form length, you may need to set the top margin, the bottom margin, and the actual number of lines to be printed on the page. The cut sheet feeder normally creates a two-line unprintable top margin. Therefore, if you want a total top margin of six lines (one inch), set the top margin in your software to four lines. The sheet feeder usually creates an unprintable bottom margin of about three lines, so to create a total bottom margin of six lines, set the bottom margin in your software to three lines. With a total page length of 61 printable lines, for example, the number of printed lines per page would be 54 (9 inches).

Some software designed only for printing on continuous forms does not use the form feed command recommended for sheet feeder operation. The software may not have a sheet feeder setup mode or allow for margin settings, and may only use line feeds to advance to the next form. Your sheet feeder can still work with most of these applications. Simply insert the paper you will be using into the sheet feeder, use the self test to print out the number of printable lines, and then use that number of lines as the page length setting in your software. If you change paper sizes, repeat this process. Your sheet feeder will work as if it were feeding a continuous form. If your software does not allow you to set the page length, consult your software manufacturer.

The following is a typical example of a software setup required for proper operation of your cut sheet feeder. Not all software is set up the same, so a bit of experimentation may be required before you find the best equivalent settings to use. To maintain 54 printed lines per page:

	Continuous form settings		New cut sheet feeder settings
Change page length from	66	t0	61
Change top margin from	6	t0	4
Change bottom margin from	6	t0	3

Many word processors and other software programs give you two ways to change these settings:

- 1 You can change the settings in each individual file you print.
- 1 You can change the program's default settings so that every time you use the program, these new settings are in effect.

If your program has additional features, such as headers and footers, you have to compensate accordingly.

## Control panel operation

All of the functions from the control panel are available in cut sheet feeder mode. You can use micro-adjustment to change the loading position immediately after loading a sheet using the single sheet insertion method described on page 7-14. Micro-adjustment sets a new sheet loading position for as long as the power remains on. If **the** power is turned off, the loading position returns to **the** factory setting. Changing the loading position with micro-adjustment affects **the** number of lines per page. You may need to change your software margin settings again for this new page length. See the section on micro-adjustment in Chapter 2.

## Testing the printer in the cut sheet feeder mode

The printer's built-in self test in the cut sheet feeder mode is slightly different from that of **the** original self test. To test the printer in cut **sheet** feeder mode, load the paper you will be using into the paper bin. Hold down the **LINE FEED** or **FORM FEED** button and turn the power switch on as described in Chapter 1.

When you perform the cut sheet feeder self test, the printer counts the number of lines on the page and prints out this number at the bottom of the first page as **shown** in the following figure. The number of lines counted by the printer becomes the new default page length setting for the cut sheet feeder mode. You can override this setting, however, using software commands.

The self test is especially useful when you want to change **the** page length settings for your application program, because it gives you a quick count of the number of lines on the page.

Below is a portion of the first page of a self test in cut sheet feeder mode. The remainder of the self test is similar to the original self test described in Chapter 1.

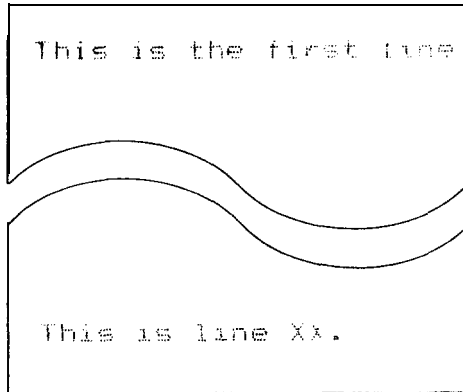

**WARNING:** Never perform the self test on envelopes.

### Switching from the cut sheet feeder to continuous paper

The FX allows you to switch between cut sheet feeder paper and continuous paper easily without having to remove either the feeder or the continuous paper supply. To switch between these two paper feeding methods, follow the steps below.

1. Make sure the continuous paper is already loaded and in a standby position, as explained in the section on switching between single sheets and continuous paper in Chapter 2.
2. Install the cut sheet feeder as described in this section, making sure that DIP switch 2-2 is set to on, and that the paper release lever is pushed all the way back to the single sheet position.

3. To switch from cut **sheet** feeder operation to continuous paper, pull the paper release lever all the way forward to the continuous paper position. You do not need to change the DIP switch setting.
4. Raise the paper path guide on the cut sheet feeder until it clicks open, as shown below. This guide directs the flow of continuous paper out of the **front** of the printer.

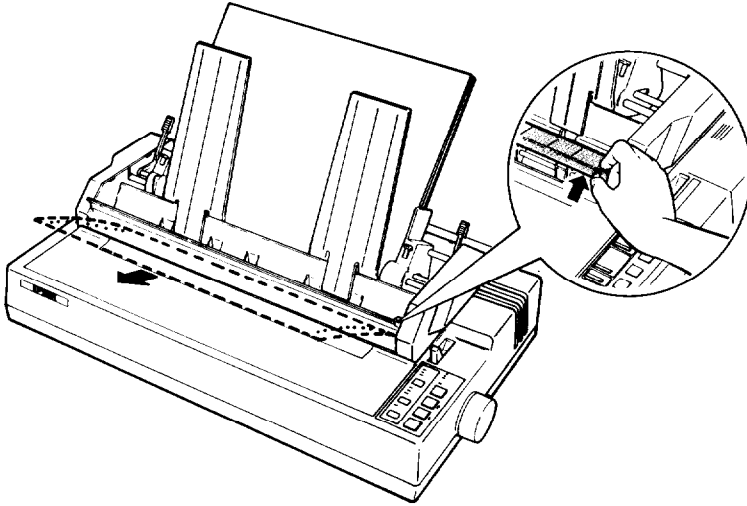

5. With the paper release lever forward, **the** control panel functions normally. This allows you to use micro-adjustment to adjust the loading position of your paper.
6. To switch back to **the** cut sheet feeder, push **the LOAD/EJECT** button until the continuous paper feeds backward out of **the** paper path and into a standby position. Push **the** paper release lever back to put the printer into the sheet feeder mode, and then close the paper path guide.

## Single sheet insertion

Your cut sheet feeder also **has a** single sheet loading feature. This feature allows you to **switch** to a different type of paper (such as letterhead) without replacing **the** supply of paper that is loaded in your cut **sheet** feeder. Single sheet insertion is especially useful because it allows you to use micro-adjustment to change your cut **sheet** feeder loading position.

1. Press the **ON LINE** button to take the printer off line.
2. Align the single sheet to be fed with the marking on the left paper guide, and then slide the sheet into the printer path until you feel resistance.

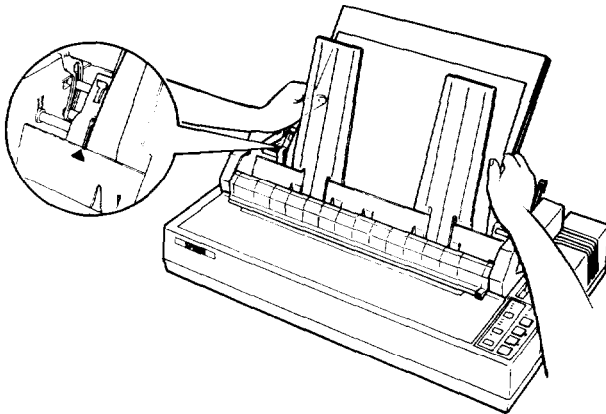

3. Press the **LOAD/EJECT** button to load the sheet.

**Note:** If you want to use single sheet insertion for two or more consecutive pages, pull the cut sheet feeder's paper set levers forward; otherwise, the next sheet is loaded from paper stored in the cut sheet feeder bin.

4. Press the **ON LINE** button to put the printer **on** line. Now you can use micro-adjustment to change the loading position for your cut sheet feeder. See the section on micro-adjustment in Chapter 2.

## The Pull Tractor

The optional pull tractor (#7311 for the FX-850 and #7312 for the FX-1050) provides optimum continuous paper handling. The pull tractor is especially useful with continuous multi-part forms and labels. For best results, use the pull tractor along with the built-in push tractor, as described in this section.

After making sure that you have both parts of the pull tractor option as shown below, remove the packing material and save it in case you need to ship the unit later.

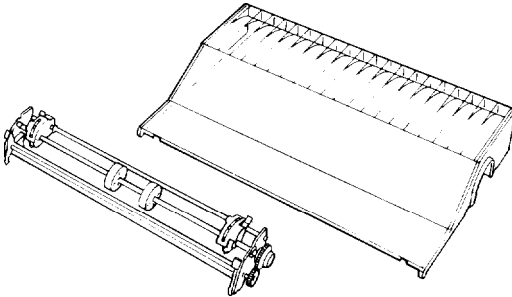

**Caution:** The short tear-off function cannot be used with the pull tractor. Before you start printing with the pull tractor, make sure that DIP switch 1-5 is set to on. (Short tear-off is turned off only when the DIP switch is set to on. See the section on setting DIP switches in Chapter 3.)

### Installation and use

After making sure that the printer is turned off, install and use the pull tractor as follows:

1. Remove the printer cover and the paper guide and install the paper rest if you haven't already. (See Chapter 2.)

2. Remove the paper tension unit by pressing open the release levers and lifting up the front of the unit at the same time.

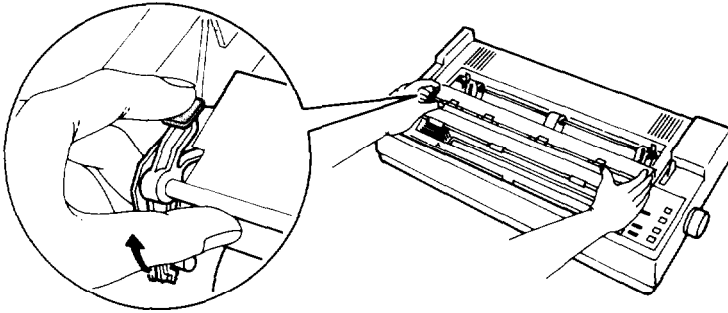

3. Hold the pull tractor with the gears to the right and fit the rear notches on the tractor over the rear mounting pins on the printer as shown below.

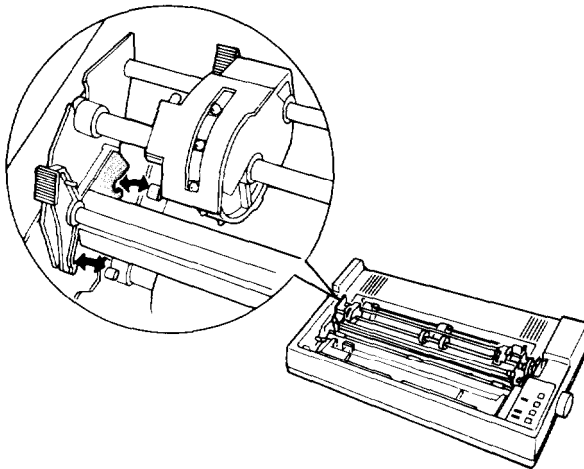

4. Tilt the tractor unit toward you until the front latches click in place over the front mounting pins of the printer.
5. Now load paper as described in the section on loading continuous paper in Chapter 2. However, position the left sprocket unit about 1/4 of an inch from the left before locking it in place.
6. After the paper is loaded in the push tractor, make sure the printer is off line and then press the FORM FEED button. This advances the paper one page so you can fit the paper onto the pull tractor.

Caution: Never use the platen knob to feed the paper while the printer is turned on. If you need to adjust the loading position, use the micro-adjustment function described in Chapter 2.

7. Open the sprocket covers, and release the sprocket lock levers.

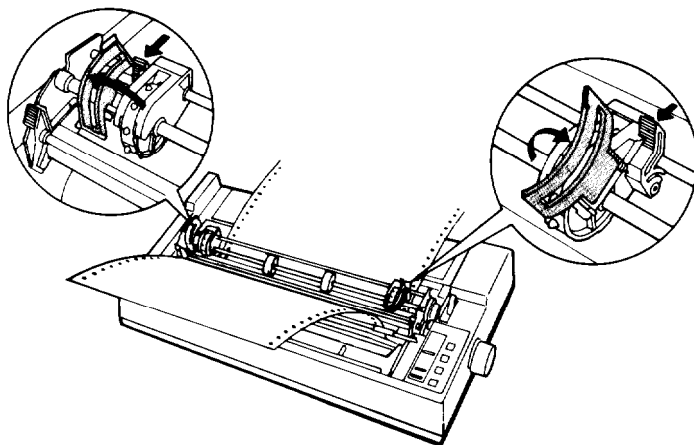

8. Move the sprocket units to match the width of the paper and adjust the paper supports so they are evenly placed between the sprocket units. (There is only one paper support on the FX-850 pull tractor.)

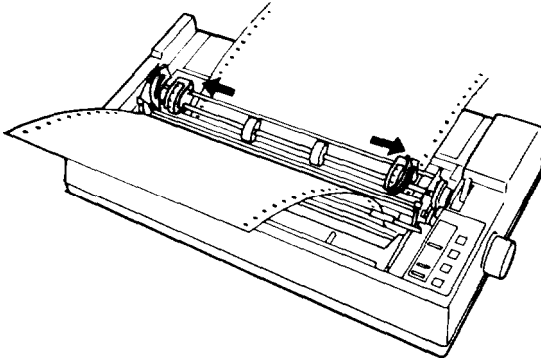

9. Fit the holes of the paper over the tractor pins of the sprocket units, adjusting the position of the sprocket units as necessary.

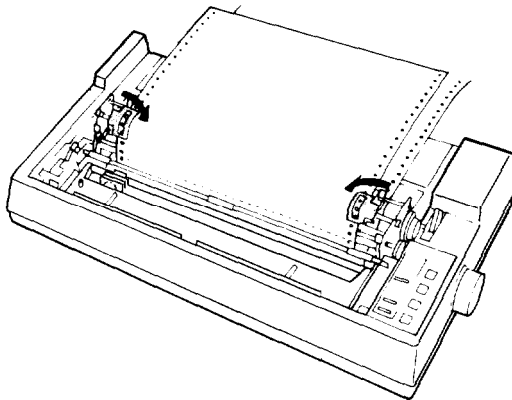

10. If the paper does not fit exactly onto the tractor pins, press in on the pull tractor feed knob and turn it in the desired direction.

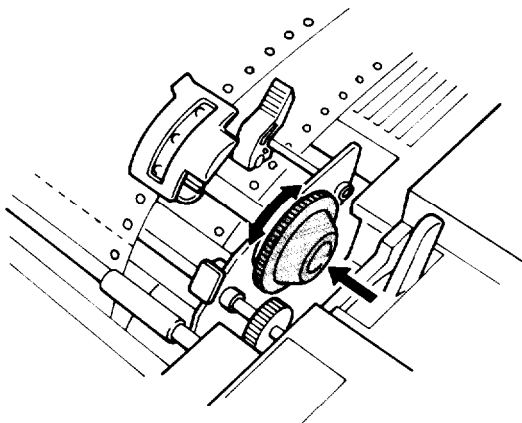

11. Close the sprocket covers.
12. Make sure that the paper is not crooked or wrinkled and then lock the sprocket units in place.

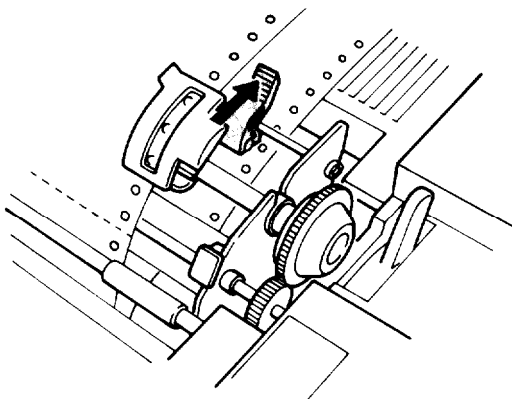

- Slide the rollers on the paper bail so they are evenly distributed across the width of your paper. Also, make sure that the right and left rollers are at both edges of your paper.

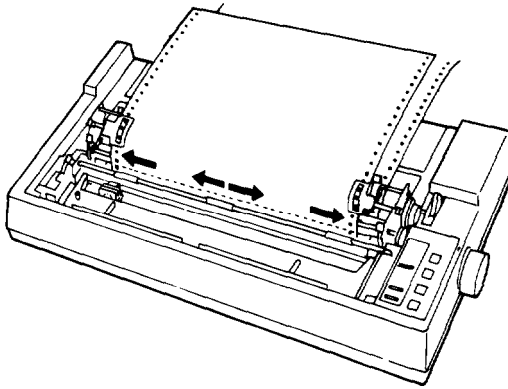

- Re-install the paper guide and then slide the edge guides together so they meet at about the middle of the paper's width.
- Install the pull tractor cover.

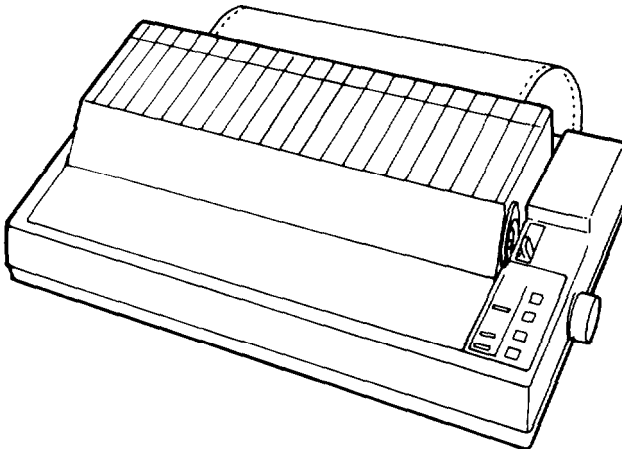

16. Press the **ON LINE** button to put the printer on line. Now you are ready to begin printing.

### **When you are finished printing**

The short tear-off function cannot be used with the pull tractor. If you want to tear off the last printed page at its perforation, press the **ON LINE** button to take the printer off line and press the **FORM FEED** button to feed the paper forward an additional page before tearing off the paper.

### **Using the pull tractor alone**

If you wish, you can use the pull tractor without using the push tractor. To do this, feed the paper from the rear, above the metal guide, and then load it. Be sure to pull the paper release lever forward to the continuous paper position after you load the paper.

### **Removing the pull tractor**

After turning off the printer and removing the pull tractor cover, remove the pull tractor as follows:

1. Pressing the tabs on the pull tractor, tilt it back and lift it off the printer.

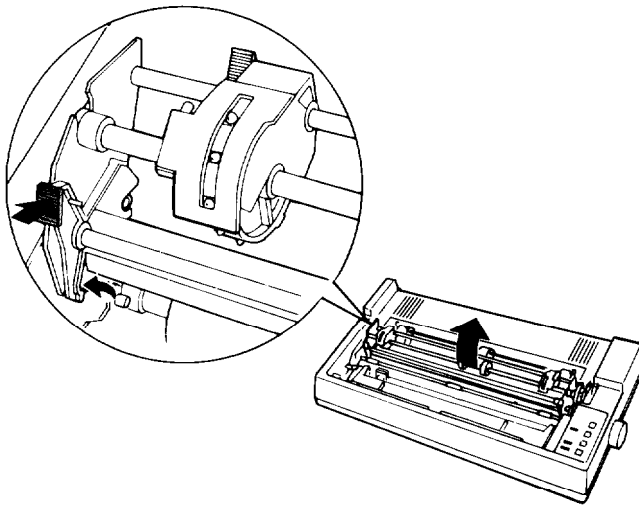

2. Replace the paper tension unit as shown below.

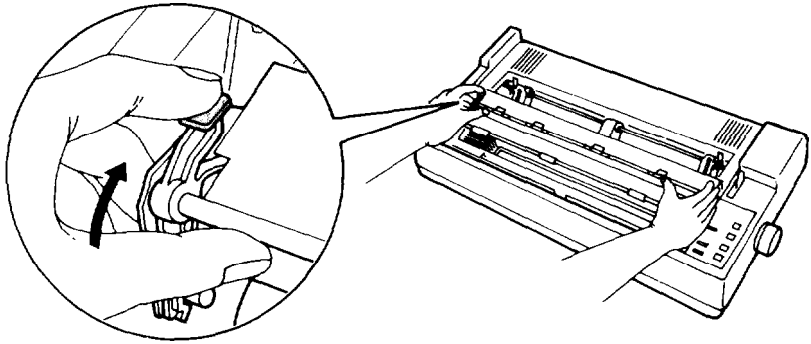

3. Now you are ready to use either single sheets or the push tractor.

## Interface Boards

There are a number of optional interfaces that can be used to supplement the capabilities of your printer's built-in parallel interface.

### Choosing an interface

Optional interfaces can be divided into three main categories:

- IEEE-488 interfaces offer standardized connections, trouble-free operation, and the ability to connect computers, printers, and other devices on the same line so that they can share data freely.
- Buffered parallel interfaces give the printer more memory and free up the computer for other tasks when printing large amounts of text or graphics. With a buffered parallel interface, you can increase the printer's data buffering capacity to 32 Kbytes (about 10 pages). Parallel interfaces also offer the advantage of trouble-free operation combined with standardized connectors.

- Serial interfaces are necessary if your computer is not equipped with a parallel interface or if you need an interface that conforms to the Current Loop standard instead of the RS-232C. In addition, all available serial interface boards provide user-selectable baud rates and data word structures. These interfaces also offer some combination of the following features: X-on/X-off data communication protocol, loopback self-test modes, and data buffers that increase the printer's buffering capacity to either 32 Kbytes or 128 Kbytes.

If you are still unsure whether you need an optional interface, or would like to know more about interfaces, contact your Epson dealer.

### Compatible interfaces

The Epson interfaces that are compatible with the FX-850 and FX-1050 are listed below.

Interface number	Name
#8143	RS-232/current loop interface
#8148	Intelligent serial interface
#8149	32Kbyte buffer serial interface
#8165	Intelligent IEEE-488 interface
#8172	32 Kbyte buffer parallel interface

### Removing the upper case

Before installing an optional interface board, you must remove the upper case. This is easy to do; the only tool you need is a Phillips screwdriver. Follow the instructions below:

1. Turn off both the printer and the computer, unplug the printer from the electrical outlet, and disconnect the parallel cable from the printer and computer.



**WARNING:** High voltage is present inside the printer when the power is on. Do not attempt to remove the upper case unless the printer is turned off and the power cord is unplugged. Also, do not touch contacts on the printer's circuit board because many of the components can be destroyed by static electricity built up in your body.

2. Remove the printer cover, paper guide, ribbon cartridge, and any installed options.
3. Remove the platen knob and push the paper release lever back to the single sheet position.
4. Remove the screw located inside the front center of the upper case.

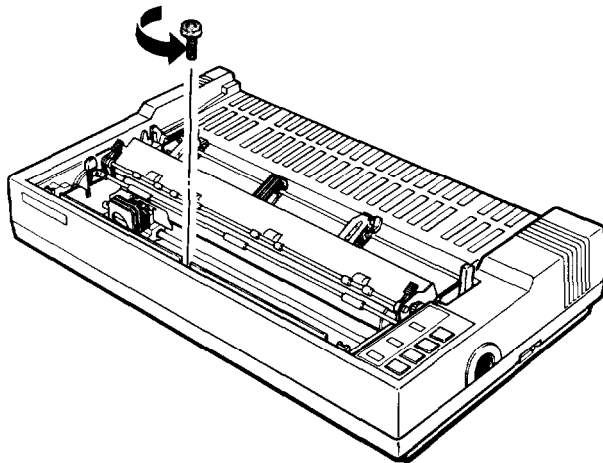

5. Reach inside the front cover and push in on the upper case fastening clips. These clips are located on both sides of the printer case. Push both clips at the same time as shown in the figure below.

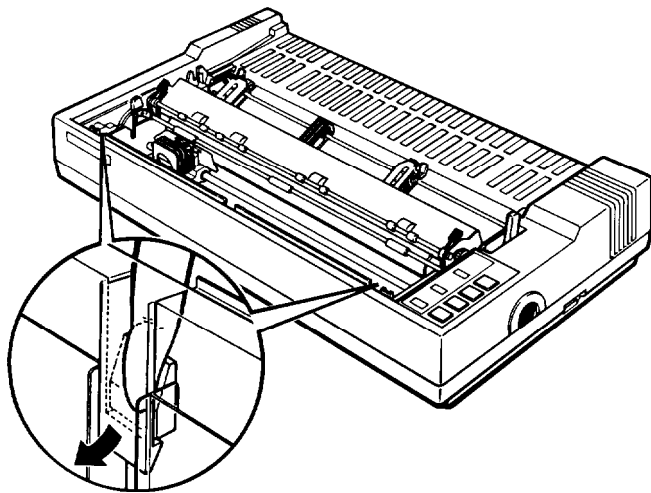

6. Raise the upper case slightly (about six inches), taking care not to strain the flat cable attached to the control panel.

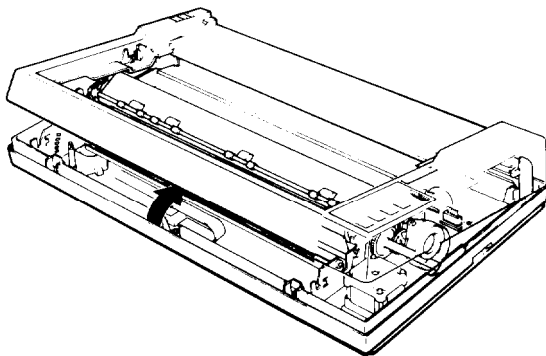

7. Carefully disconnect the control panel cable from the connector labelled CN11 on the main board.

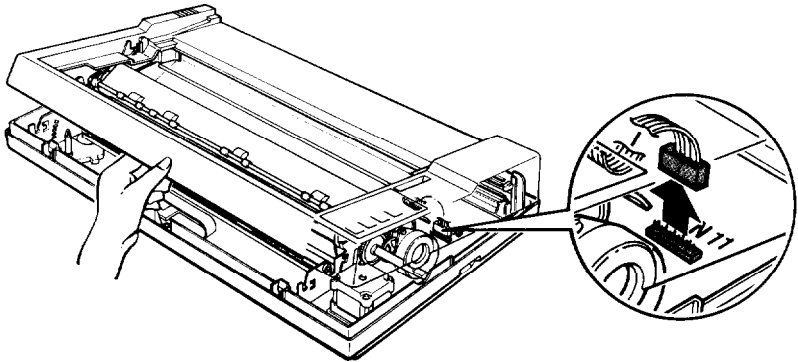

8. Tilt the upper case backward and lift it clear of the printer body.

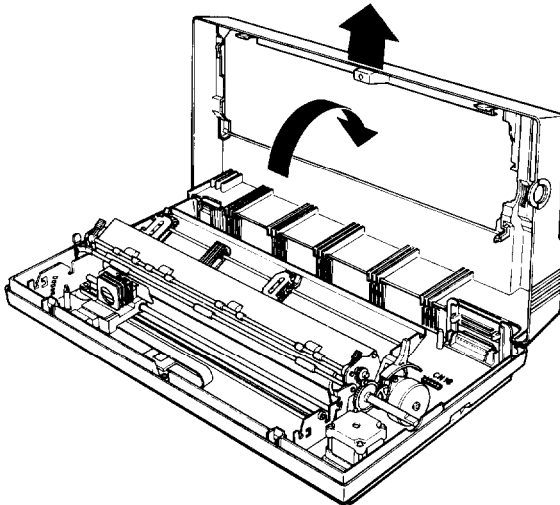

**Caution:** Be very careful when removing or attaching the upper case to avoid damaging the printer.

9. Remove the option interface shield plate by pressing in on the plastic clips located at the back of the plate.

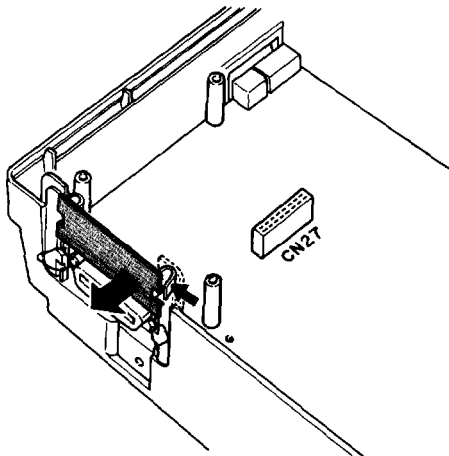

10. Remove the screw labelled CG from the main board.

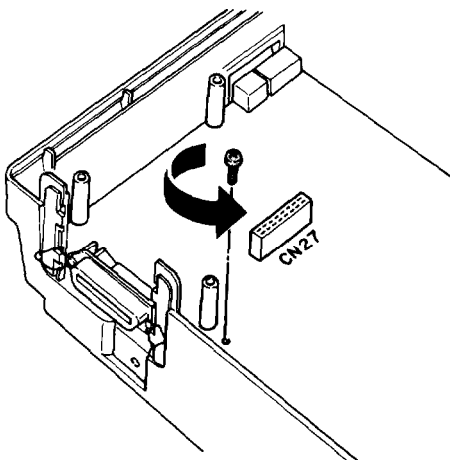

## Installing the board

There are two basic interface board designs. These boards differ with respect to how the frame ground (FG) wire is attached. This slight difference changes the way the boards are installed in the printer, but does not affect the operation of the interface in any way. Look at the following illustration to see which type of interface board you have and then follow the installation procedure for that type of board.

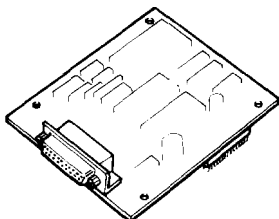

FG wire not attached  
See below

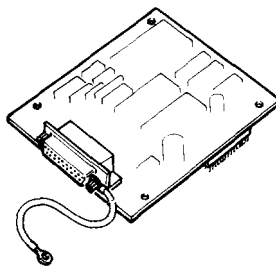

FG wire attached  
Skip to next section

### FG wire not attached

1. Use the CC screw to attach the round end of the FG (frame ground) wire to the main board and position the other end as shown.

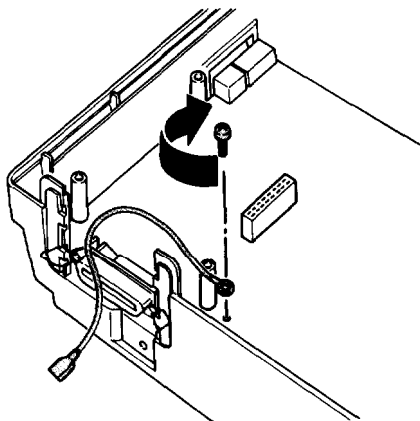

2. Carefully insert the pins on the optional interface board into the mating connector on the main board. Secure the board with the three screws provided.

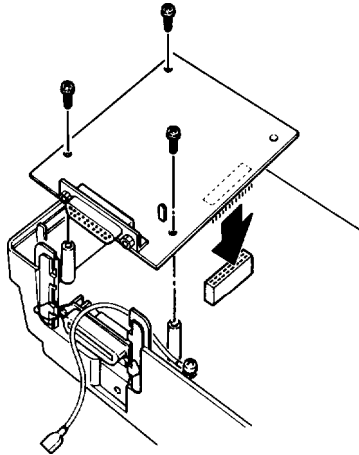

3. Attach the plug end of the FG wire onto the FG pin located on top of the interface board.

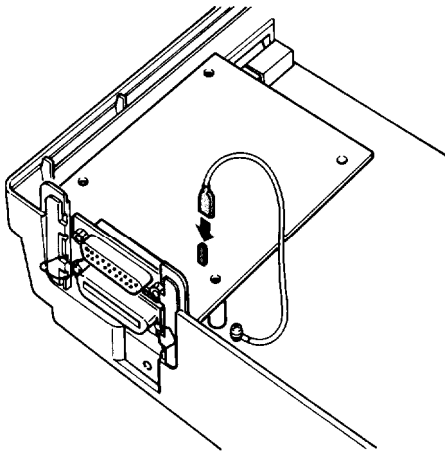

4. Set the DIP switches on the interface board according to the manual that comes with the board.

## FG wire attached

1. Carefully place the interface board next to the printer as shown below. Use the CG screw to connect the round end of the FG (frame ground) wire to the main board.

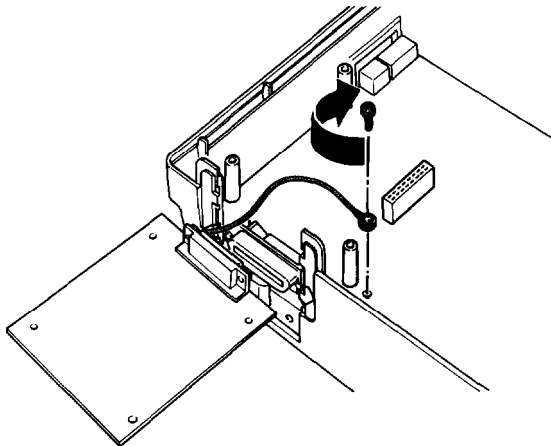

2. Holding the interface board level, rotate it clockwise into position and attach it to the main board. Make sure that the connector pins are properly inserted into the mating connector.

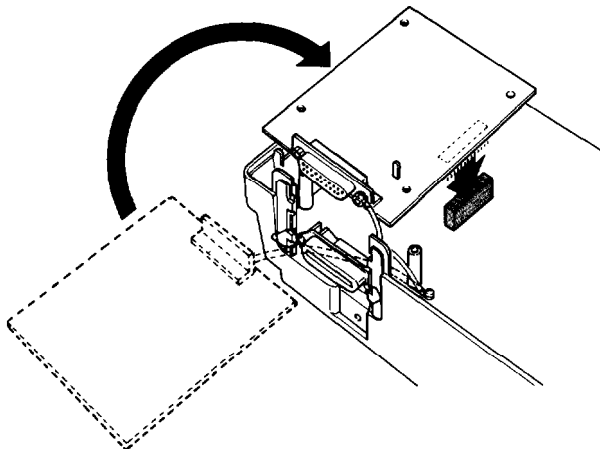

3. Secure the board with the three screws provided.

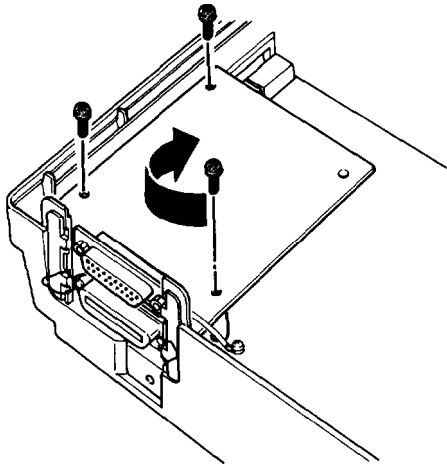

4. Set the DIP switches on the interface board according to the manual that comes with the board.

### Attaching the upper case

1. Fit the hinges of the upper case into the openings in the lower case. Then partially lower the upper case.

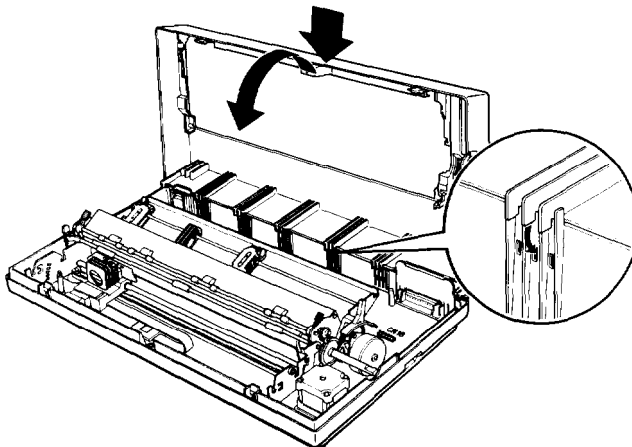

**Caution:** Take care not to pinch the FG wire between the upper and lower cases.

2. Carefully insert the control panel cable into the connector labelled CN11 on the main board.

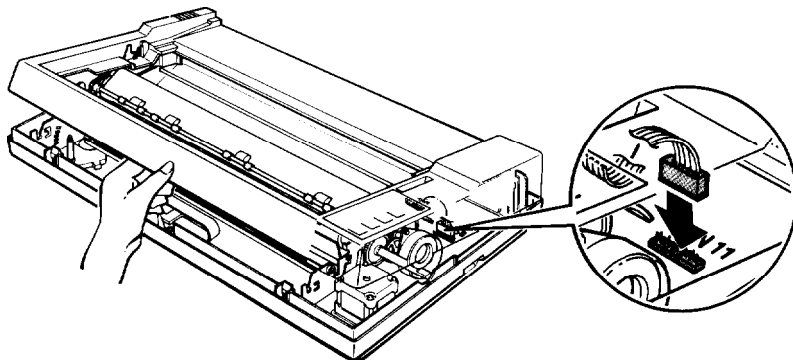

3. Close the upper case. Make sure you press down on the front of the case until it locks into place.

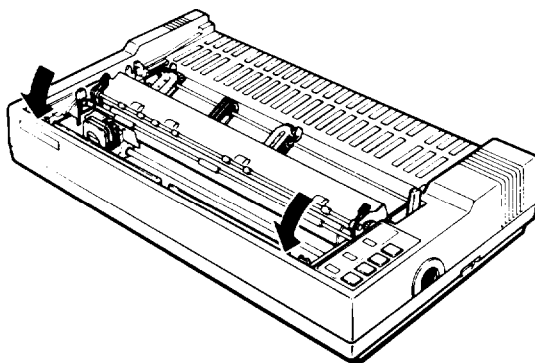

4. Insert and tighten the screw to secure the upper case, and then reattach the platen knob.

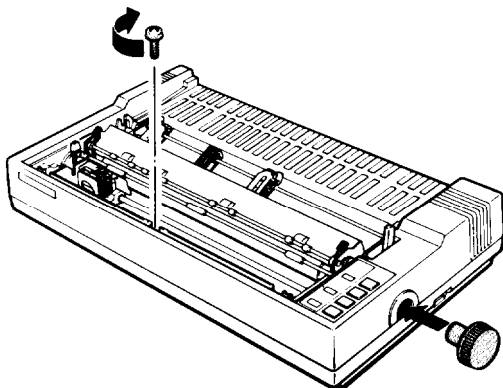

**WARNING:** When installing an optional interface board, be sure to disconnect the printer cable from the printer's built-in parallel interface. Two interface cables must not be installed at the same time.

This completes the installation of the optional interface board. Replace the ribbon cartridge, printer cover, and any other necessary parts or options.

# Command Summary

This chapter lists and describes all the commands, both Epson (ESC/P) mode and IBM emulation mode, available on the FX.

The first part of this appendix lists all commands in numerical order and gives the page number where each is fully described. If you know which command you are looking for, consult the numerical list to find the page number where it is described.

The Quick Reference card at the end of the book also contains a list of the commands divided by topic, with page number references that direct you to full explanations of the commands. The numerical list and the Quick Reference card also show the differences between the Epson mode and the IBM emulation mode.

The second part of this appendix lists and describes Epson mode commands and IBM emulation mode commands separately; the commands are divided into the following subjects:

Printer Operation	Print Enhancement
Data Control	Word Processing
Vertical Motion	Character Sets
Horizontal Motion	User-Defined Characters
Overall Printing Style	Graphics
Print Size	

Each command has a format section and a comment section. The format section gives the ASCII, decimal, and hexadecimal values for the command; the comment section describes the effect of the command and gives any additional information necessary for using it.

All three formats are equivalent, and it should be easy to pick the one most suited to your purpose.

**Note:** Some application programs can use control key sequences. See the Control Key chart on page 8-3 for information on using these.

The simplest type of command consists of a single character to be sent to the printer. For instance, to print in condensed mode the code format is:

```
ASCII code: SI
Decimal:    15
Hexadecimal: 0F
```

This code can be sent from a program by sending the code 15 directly.

More complex commands consist of two or more character codes. For example, to print in double-wide mode the code format is the following:

```
ASCII code:  ESC    W    n
Decimal:     27    87    n
Hexadecimal: 1B    57    n
```

In this case *n* can be either 1 or 0, to begin or end double-wide printing. You can use either of the following commands to turn ON double-wide print from BASIC:

```
LPRINT CHR$(27);CHR$(87);CHR$(1)
LPRINT CHR$(27);"W";CHR$(1)
```

For the following commands that use only 0 or 1 for the variable, either the ASCII codes 1 and 0 or the ASCII characters 1 and 0 can be used:

```
ESC s, ESC U, ESC x, ESC p, ESC W, ESC S, ESC-, ESC w, and
ESC %
```

For example, in BASIC you can turn on double-high with either of these statements:

```
LPRINTCHR$(27);"w";CHR$(1)
LPRINT CHR$(27);"w";"1"
```

## Control key chart

Some application programs can use control key codes for decimal values 0 through 27. The table below gives you the proper values. The Control Key column indicates that you press the control key at the same time you press the key for the letter or symbol in that column. For example, you press the control key and A at the same time to send the value 1.

Note: Many programs use the control keys for other purposes. Also, some programs do not use all these keys.

Dec.	Hex.	Control Key
0	00	@
1	01	A
2	02	B
3	03	C
4	04	D
5	05	E
6	06	F
7	07	G
8	08	H
9	09	I
10	0A	J
11	0B	K
12	0C	L
13	0D	M
14	0E	N
15	0F	O
16	10	P
17	11	Q
18	12	R
19	13	s
20	14	T
21	15	U
22	16	V
23	17	W
24	18	X
25	19	Y
26	1A	Z
27	1B	[

# Commands in Numerical Order

This section lists all the FX commands, with their decimal and hexadecimal values. The numbers in the columns on the right are the page numbers in this chapter where a complete description of the command can be found. If the Epson and IBM emulation mode page numbers are the same, the command is the same in both modes and is described only in the Epson mode section.

<i>ASCII</i>	<i>Decimal</i>	<i>Hexadecimal</i>	<i>Description</i>	<i>Epson Mode</i>	<i>IBM Emulation Mode</i>
BEL	7	07	Beeper	8-12	8-12
BS	8	08	Backspace	8-20	8-20
HT	9	09	Tab horizontally	8-22	8-22
LF	10	0A	Line feed	8-15	8-15
VT	11	0B	Tab vertically	8-18	8-18
FF	12	0C	Form feed	8-14	8-14
CR	13	0D	Carriage return	8-13	8-13
SO	14	0E	Select double-wide (1 line)	8-27	8-27
SI	15	0F	Select condensed mode	8-26	8-26
DC1	17	11	Select printer	8-8	8-8
DC2	18	12	Cancel condensed mode	8-26	
DC2	18	12	Cancel condensed/12 cpi prop.		8-47
DC3	19	13	Deselect printer	8-9	
DC4	20	14	Cancel double-wide (1 line)	8-27	8-27
CAN	24	18	Cancel line	8-13	8-13
DEL	127	7F	Delete character	8-13	
ESC SO	14	0E	Select double-wide (1 line)	8-27	8-27
ESC SI	15	0F	Select condensed mode	8-26	8-26
ESC EM	25	19	Cut sheet feeder on/off	8-11	
ESC SP	32	20	Set intercharacter space	8-32	
ESC !	33	21	Master Select	8-24	
ESC #	35	23	Cancel MSB control	8-12	
ESC \$	36	24	Set absolute print position	8-21	
ESC %	37	25	Select user-defined set	8-36	

ASCII	Decimal	Hexadecimal	Description	Epson Mode	IBM Emulation Mode
ESC &	38	26	Define user-defined characters	8-35	
ESC *	42	2A	Select graphics mode	8-39	
ESC -	45	2D	Turn underlining on/off	8-31	8-31
ESC /	47	2F	Select vertical tab channel	8-19	
ESC 0	48	30	Select 1/8-inch line spacing	8-16	8-16
ESC 1	49	31	Select 7/72-inch line spacing	8-16	8-16
ESC 2	50	32	Select 1/6-inch line spacing	8-16	
ESC 2	50	32	Programmable line spacing		8-43
ESC 3	51	33	Select n/216-inch line spacing	8-17	8-17
ESC 4	52	34	Select italic mode	8-33	
ESC 4	52	34	Set top of form		8-43
ESC 5	53	35	Cancel italic mode	8-34	
ESC 5	53	35	Turn automatic line feed on/off		8-44
ESC 6	54	36	Printable code area expansion	8-36	
ESC 6	54	36	Select international character set		8-49
ESC 7	55	37	Cancel ESC 6	8-37	
ESC 7	55	37	Select standard character set		8-49
ESC 8	56	38	Disable paper-out sensor	810	
ESC 9	57	39	Enable paper-out sensor	S-10	
ESC :	58	3A	Copy ROM into RAM	8-35	
ESC :	58	3A	Select 12 cpi		8-46
ESC <	60	3C	Unidirectional mode (1 line)	8-9	
ESC =	61	3D	Set MSB to 0	8-11	
ESC =	61	3D	Define user-defined characters		8-50
ESC >	62	3E	Set MSB to 1	8-12	
ESC ?	63	3F	Reassign graphics mode	8-40	
ESC @	64	40	Initialize printer	8-8	
ESC A	65	41	Select n/72-inch line spacing	8-17	
ESC A	65	41	Set n/72-inch line spacing		8-42
ESC B	66	42	Set vertical tabs	8-18	8-18

ASCII	Decimal	Hexadecimal	Description	Epson Mode	IBM Emulation Mode
ESC C	67	43	Set page length in lines	8-14	8-14
ESC C 0	67	43	Set page length in inches	8-14	8-14
ESC D	68	44	Set horizontal tabs	8-22	8-45
ESC E	69	45	Select emphasized mode	8-29	8-29
ESC F	70	46	Cancel emphasized mode	8-29	8-29
ESC G	71	47	Select double-strike mode	8-29	8-29
ESC H	72	48	Cancel double-strike mode	8-30	8-30
ESC I	73	49	Printable code area expansion	8-37	
ESC I	73	49	Select font		8-46
ESC J	74	4A	Perform <i>n</i> /216-inch line feed	8-17	8-43
ESC K	75	4B	Select single-density graphics	8-38	8-38
ESC L	76	4C	Select double-density graphics	8-38	8-38
ESC M	77	4D	Select 12 cpi	8-25	
ESC N	78	4E	Set skip over perforation	8-15	8-15
ESC O	79	4F	Cancel skip over perforation	8-15	8-15
ESC P	80	50	Select 10 cpi	8-24	
ESC P	80	50	Turn proportional on/off		8-47
ESC Q	81	51	Set right margin	8-20	
ESC Q3	81	51	Deselect printer (FX-850)		8-42
ESC Q22	81	51	Deselect printer (FX-1050)		8-42
ESC R	82	52	International character set	8-34	
ESC R	82	52	Restore default tab settings		8-45
ESC S0	83	53	Select superscript mode	8-30	8-30
ESC S1	83	53	Select subscript mode	8-30	8-30
ESC T	84	54	Cancel superscript/subscript	8-31	8-31
ESC U	85	55	Turn unidirectional mode on/off	8-10	8-10
ESC W	87	57	Turn double-wide on/off	8-28	8-28
ESC X	88	58	Set left and right margins		8-44
ESC Y	89	59	High-speed dbl-density graphics	8-38	8-38
ESC Z	90	5A	Quadruple-density graphics	8-39	8-39
ESC [@	91	5B	Double-high double-wide on/off		8-48

<i>ASCII</i>	<i>Decimal</i>	<i>Hexadecimal</i>	<i>Description</i>	<i>Epson Mode</i>	<i>IBM Emulation Mode</i>
ESC \	92	5C	Set relative position	8-21	
ESC \	92	5C	Print characters from symbol set		8-49
ESC ^	94	5E	Select 9-pin graphics	8-40	
ESC ^	94	5E	Print 1 char. from symbol set		8-50
ESC _	95	5F	Turn overscore on/off		8-48
ESC a	97	61	Select justification	8-32	
ESC b	98	62	Set vertical tabs in channels	8-18	
ESC k	107	6B	Select NLQ font	8-23	
ESC l	108	6C	Set left margin	8-19	
ESC p	112	70	Turn proportional mode on/off	8-25	
ESC s	115	73	Turn half-speed mode on/off	8-9	
ESC t	116	74	Select character table	8-33	
ESC w	119	77	Turn double-high on/off	8-28	
ESC x	120	78	Select NLQ or draft	8-23	

# Epson (ESC/P) Commands

The following section lists and describes all the Epson (ESC/P) commands.

## Printer Operation

Initialization

ESC @ Initialize Printer

---

Format:

ASCII code:	ESC	@
Decimal :	27	64
Hexadecimal:	1B	40

Comments:

Resets the printer mode and clears the buffer of printable data on the print line preceding the command.

Selection

DC1 Select Printer

---

Format:

ASCII code:	DC1
Decimal :	17
Hexadecimal:	11

Comments:

Returns the printer to the selected state if it has been deselected by the printer deselect code (DC3). Does not select the printer if it has been switched off line by pressing the ON LINE button. DC1 and DC3 do not work if pin 36 on the parallel interface is low (for example, on IBM and some compatible computers).

## Format:

ASCII code: DC3  
 Decimal : 19  
 Hexadecimal: 13

## Comments:

Puts the printer into the deselected state until select printer code (DCI) is received. The printer cannot be reselected with the ON LINE button.

## Speed

---

ESC s Turn Half-Speed Mode On/Off

## Format:

ASCII code:	ESC	s	n
Decimal:	27	115	n
Hexadecimal:	1B	73	n

## Comments:

The following values can be used for *n*:

- 1: Mode is turned ON. (The ASCII codes 0 and 1 or the ASCII characters "0" and "1" can be used.)
- 0: Mode is turned OFF.

## Printing direction

---

ESC ( Select Unidirectional Mode (one line)

## Format:

ASCII code:	ESC	(
Decimal:	27	60
Hexadecimal:	1B	3C

## Comments:

Printing is normally bidirectional. This command selects unidirectional printing for one line only. (It is cancelled by a carriage return.) The print head moves to the extreme left (home) position, and printing takes place from left to right.

## Format:

ASCII code:	ESC	U	<i>n</i>
Decimal:	27	85	<i>n</i>
Hexadecimal:	1B	55	n

## Comments:

The following values can be used for *n*:

- 1: Mode is turned ON. (The ASCII *codes* 0 and 1 or the ASCII characters "0" and "1" can be used.)
- 0: Mode is turned OFF.

Printing is normally bidirectional. This command selects unidirectional printing for more accurate positioning.

## Format:

ASCII code:	ESC	8
Decimal:	27	56
Hexadecimal:	1B	38

## Comments:

Turns off the paper-out sensor so that you can print to the end of a single sheet of paper.

## Format:

ASCII code:	ESC	9
Decimal:	27	57
Hexadecimal:	1B	39

## Comments:

Cancels ESC 8. Therefore, the printer beeper sounds and printing stops when the printer reaches a point approximately 1/2 of an inch from the end of the paper.

## Format:

ASCII code:	ESC	EM	<i>n</i>
Decimal :	27	25	<i>n</i>
Hexadecimal:	1B	19	<i>n</i>

## Comments:

The following values can be used for *n*:

4: Mode is turned ON.

0: Mode is turned OFF.

The variables are the characters “0” (48 decimal) and “4” (52 decimal).

The command should not be used unless the cut sheet feeder is installed. It is ignored if any value other than “0” or “4” is used for *n*. The mode can also be turned on or off with DIP switch 2-2.

## MSB control

Note: MSB is the Most Significant Bit. **MSB control (ESC =, ESC >, and ESC #) is not valid for graphics or user-defined characters.**

## ESC = (equal)

Set MSB to 0

## Format:

ASCII code:	ESC	=
Decimal:	27	61
Hexadecimal:	1B	3D

## Comments:

Sets the MSB of all incoming data to 0. Some computers always send data with the MSB set to 1, which means that italics or character graphics are always printed. ESC = can overcome this problem.

## Format:

ASCII code:	ESC	>
Decimal:	27	62
Hexadecimal:	1B	3E

## Comments:

Sets the MSB bit of all incoming data as 1.

---

ESC #Cancel MSB Control

---

## Format:

ASCII code:	ESC	#
Decimal:	27	35
Hexadecimal:	1B	23

## Comments:

Cancels the MSB control set by ESC = or ESC >.

**Beeper**

---

BELBeeper

---

## Format:

ASCII code:	BEL
Decimal:	7
Hexadecimal:	07

## Comments:

Sounds the printer's beeper.

## Data Control

CR Carriage Return

---

Format:

ASCII code: CR  
Decimal: 13  
Hexadecimal : 0D

Comments:

Prints the data in the buffer and returns the print position to the left margin. A line feed may be added if DIP switch 2-4 is ON or if the AUTO FEED XT line on the parallel interface is held LOW.

CAN Cancel Line

---

Format:

ASCII code: CAN  
Decimal : 24  
Hexadecimal: 18

Comments:

Removes all text on the print line but does not affect control codes.

DEL Delete Character

---

Format:

ASCII code: DEL  
Decimal: 127  
Hexadecimal: 7F

Comments:

Removes the last text character on the print line but does not affect control codes.

## Vertical Motion

Form feeding

FF

Form Feed

---

Format:

ASCII code: FF

Decimal: 12

Hexadecimal: 0C

Comments:

Prints the data in the print buffer and advances the paper to the top of the next form according to the current page length.

ESC C

Set Page Length in Lines

---

Format:

ASCII code: ESC C n

Decimal: 27 67 n

Hexadecimal: 1B 43 n

Comments:

Sets the page length to n lines in the current line spacing. The value of n must be from 1 to 127. The top of form position is set to the current line. Overrides the DIP switch page length setting.

ESC C 0

Set Page Length in Inches

---

Format:

ASCII code: ESC C 0 n

Decimal : 27 67 0 n

Hexadecimal: 1B 43 00 n

Comments:

Sets the page length to n inches. The value of n must be from 1 to 22. The top of form position is set to the current line. Overrides the DIP switch page length setting.

## Format:

ASCII code:	ESC	N	<i>n</i>
Decimal:	27	78	<i>n</i>
Hexadecimal:	1B	4E	<i>n</i>

## Comments:

The variable *n* is the number of lines skipped between the last line printed on one page and the first line on the next page. For example, with the standard settings for line spacing (1/6-inch), and page length (66 lines), ESC N 6 causes the FX to print 60 lines and then skip 6. DIP switch 2-3 performs the same function. This setting is cancelled by ESC 0 and also by ESC C or ESC C 0. The value of *n* must be from 1 to 127.

## Format:

ASCII code:	ESC	0
Decimal:	27	79
Hexadecimal:	1B	4F

## Comments:

Cancels the skip over perforation set by ESC N. Overrides setting of DIP switch 2-3.

## Line feeding

## Format:

ASCII code:	LF
Decimal:	10
Hexadecimal:	0A

## Comments:

When this command is received, the data in the print buffer is printed and the paper advances one line in the current line spacing.

## Format:

ASCII code:	ESC	0
Decimal:	27	48
Hexadecimal:	1B	30

## Comments:

Sets the line spacing to 1/8 of an inch for subsequent line feed commands. The 0 is the character zero and not ASCII code 0.

## Format:

ASCII code:	ESC	1
Decimal :	27	49
Hexadecimal:	1B	31

## Comments:

Sets the line spacing to 7/72 of an inch for subsequent line feed commands. The 1 is the *character* one and not lower case L or ASCII code 1.

## Format:

ASCII code:	ESC	2
Decimal:	27	50
Hexadecimal:	1B	32

## Comments:

Sets the line spacing to 1/6 of an inch for subsequent line feed commands. The 2 is the *character* two and not ASCII code 2. This is the default at power on.

## Format:

ASCII code:	ESC	3	$n$
Decimal :	27	51	$n$
Hexadecimal:	1B	33	$n$

## Comments:

Sets the line spacing to  $n/216$  of an inch for subsequent line feed commands. The 3 is the *character* three and not ASCII code 3. The value of  $n$  must be from 0 to 255.

## Format:

ASCII code:	ESC	A	$n$
Decimal :	27	65	$n$
Hexadecimal:	1B	41	$n$

## Comments:

Sets the line spacing to  $n/72$  of an inch for subsequent line feed commands. The value of  $n$  must be from 0 to 85.

## Format:

ASCII code:	ESC	J	$n$
Decimal :	27	74	$n$
Hexadecimal:	1B	4A	$n$

## Comments:

Advances the paper  $n/216$  of an inch. The value of  $n$  must be from 0 to 255. This command produces an immediate line feed but does not affect subsequent line spacing and does not produce a carriage return.

VT

Tab Vertically

Format:

ASCII code: VT  
 Decimal: 11  
 Hexadecimal: 0B

Comments:

Advances the paper to the next tab setting in the channel selected by ESC /. If no channel has been selected, channel 0 is used. If no vertical tabs have been selected, the paper advances one line.

ESC B

Set Vertical Tabs

Format:

ASCII code:	ESC	B	n1	n2	.	.	.	0
Decimal:	27	66	n1	n2	...			0
Hexadecimal:	1B	42	n1	n2	.	.	.	00

Comments:

Sets up to 16 vertical tabs in the current line spacing. Tab settings are not affected by subsequent changes in line spacing. The tab settings are entered as *n1*, *n2*, etc., all from 1 to 255, in ascending order. The 0 character indicates the end of the command. All settings are stored in channel 0 (see ESC b). ESC B 0 clears the tab settings.

ESC b

Set Vertical Tabs in Channels

Format:

ASCII code:	ESC	b	c	n1	n2	.	.	.	0
Decimal:	27	98	c	n1	n2	.	.	.	0
Hexadecimal:	1B	62	c	n1	n2	.	.	.	00

Comments:

Functions the same as ESC B, except that the variable *c* selects a channel for the vertical tabs, which must be between 0 to 7. Therefore, up to eight sets of vertical tabs can be set. The channels are selected by ESC /. To clear the tabs in channel *c* use ESC b c 0.

## Format:

ASCII code:	ESC	/	c
Decimal:	27	47	c
Hexadecimal:	1B	2F	c

## Comments:

This command is used to select the vertical tab channel, with the value of *c* from 0 to 7. All subsequent vertical tab commands use the channel selected by this command. If no channel has been selected, channel 0 is used.

## Horizontal Motion

## Margins

ESC 1

Set Left Margin

## Format :

ASCII code:	ESC	1	<i>n</i>
Decimal:	27	108	<i>n</i>
Hexadecimal:	1B	6C	<i>n</i>

## Comments:

Sets the left margin to *n* columns in the current character size. Settings made in the proportional mode are treated as 10 cpi. This command clears previous tab settings and all previous characters in the print line. Use lowercase 1 (as in left), not the numeral one. The minimum space between the margins is the width of one double-wide 10 cpi character.

## Format:

ASCII code:	ESC	Q	<i>n</i>
Decimal:	27	81	<i>n</i>
Hexadecimal:	1B	51	n

## Comments:

Sets the right margin to *n* columns in the current character size.

Settings made in the proportional mode are treated as 10 cpi. This command clears previous tab settings and all previous characters in the print line. The minimum space between the margins is the width of one double-wide 10 cpi character.

## Print head movement

BS

Backspace

---

## Format:

ASCII code:	BS
Decimal:	8
Hexadecimal:	08

## Comments:

Prints out data in the print buffer, then moves the print position one space to the left. Backspacing can be performed up to, but not beyond, the left margin setting. The BS code is also ignored if ESC a 2 or ESC a 3 has been sent.

## Format:

ASCII code:	ESC	\$	n1	n2
Decimal:	27	36	n1	n2
Hexadecimal:	1B	24	n1	n2

## Comments:

This sequence specifies the distance from the currently set left margin that subsequent characters are to be printed, using this formula: total number of dots =  $n1 + (n2 \times 256)$ . Each unit equals 1/60th of an inch. The sequence is ignored and the previous setting remains effective if the position specified is beyond the right margin. This command applies to both draft and NLQ.

## Format:

ASCII code:	ESC	1	n1	n2
Decimal:	27	92	n1	n2
Hexadecimal:	1B	5C	n1	n2

## Comments:

Determines the position (relative to the current position) at which printing of following data will start. To find n1 and n2, first calculate the displacement required in 1/120ths of an inch. Send the resulting number using this formula: total number of dots =  $n1 + (n2 \times 256)$ . *If the displacement is to the left, subtract the number from 65536 before you use the formula.* The command is ignored if it would move the print position outside the current margins. This command applies to both draft and NLQ.

HT

Tab Horizontally

Format:

ASCII code: HT

Decimal: 9

Hexadecimal: 09

Comments:

Advances the print position to the next horizontal tab setting. The default settings are at intervals of eight characters in the default character size, and tab positions are not affected by subsequent changes in character size.

ESC D

Set Horizontal Tabs

Format:

ASCII code: ESC D n1 d2 . . . 0

Decimal: 27 68 n1 n2 . . . 0

Hexadecimal: 1B 44 n1 n2 . . . 00

Comments:

This command allows setting of up to 32 horizontal tabs, which are entered as n1, n2, n3, etc. (from 1 to 255) with the 0 character or any value less than the previous one terminating the command. ESC D 0 clears all tabs. The settings on power up or after an ESC @ command are every eight characters. The tab settings do not change if the character size is changed. For proportional printing the size of 10 cpi characters determines the tab positions.

## Overall Printing Style

ESC x Select Near Letter Quality or Draft

---

### Format:

ASCII code:	ESC	x	n
Decimal:	27	120	n
Hexadecimal:	1B	78	n

### Comments:

The following values can be used for n:

0: Selects the draft mode. (The ASCII codes 0 and 1 or the ASCII

1: Selects the near letter quality (NLQ) mode. characters "0" and "1" can be used.)

Overrides the `SelecType` setting. When NLQ is selected, the font used is either Roman, Sans Serif or user-defined, whichever is currently selected.

ESC k Select NLQ Font

---

### Format:

ASCII code:	ESC	k	n
Decimal :	27	107	n
Hexadecimal:	1B	6B	n

### Comments:

This command affects only the near letter quality typestyle, not draft.

The following values can be used for n:

0 = Roman

1 = Sans Serif

Overrides the `SelecType` setting.

## Format:

ASCII code:	ESC	!	<i>n</i>
Decimal:	27	33	<i>n</i>
Hexadecimal:	1B	21	<i>n</i>

## Comments:

Selects any valid combination of the modes in the table below. The variable *n* is determined by adding together the values of the desired modes from the table.

Mode	Dec	Hex
10 cpi	0	00
12 cpi	1	01
Proportional	2	02
Condensed	4	04
Emphasized	8	08
Double-strike	16	10
Double-wide	32	20
Italic	64	40
Underline	128	80

This command applies to both draft and NLQ. 10 cpi cannot be combined with 12 cpi, and proportional cannot be condensed. If both proportional and condensed are selected, proportional overrides condensed. Double-strike is ignored in NLQ.

## Print Size and Character Width

## Format:

ASCII code:	ESC	P
Decimal:	27	80
Hexadecimal:	1B	50

## Comments:

Selects 10 characters per inch printing. This command is normally used to cancel 12 cpi.

## Format:

ASCII code:	ESC	M
Decimal:	27	77
Hexadecimal:	1B	4D

## Comments:

Selects 12 characters per inch printing. This command is available in both draft and NLQ.

## ESC p

## Turn Proportional Mode On/Off

## Format:

ASCII code:	ESC	<b>p</b>	n
Decimal:	27	<b>112</b>	n
Hexadecimal:	1B	70	n

## Comments:

The following values can be used for n:

1: Mode is turned ON. (The ASCII codes 0 and 1 or the ASCII characters "0" and "1" can be used.)  
 0: Mode is turned OFF.

The width of proportional characters varies from character to character. Therefore, a narrow letter like i receives less space than a wide letter like W. The proportional widths are given in the character tables, which appear in Appendix B. This command overrides condensed. This command is available for draft, NLQ, and user-defined characters.

## Format:

ASCII code: SI  
Decimal: 15  
Hexadecimal: 0F

## Comments:

Prints characters at about 60 percent of their normal width. For example, the condensed 10 cpi mode has 17 characters per inch. Proportional mode cannot be condensed, and proportional overrides condensed. This command is available in both draft and NLQ.

## Format:

ASCII code:	ESC	SI
Decimal:	27	15
Hexadecimal:	1B	0F

## Comments:

Duplicates the SI command. This command is available in both draft and NLQ.

## Format:

ASCII code: DC2  
Decimal: 18  
Hexadecimal: 12

## Comments:

Cancels condensed printing set by SI, ESC SI, or SelecType.

**SO**Select Double-Wide Mode (one line)

---

## Format:

ASCII code: SO

Decimal: 14

Hexadecimal : 0E

## Comments:

Double-wide mode doubles the width of all characters. This mode is cancelled by a carriage return or DC4. This command is available in both draft and NLQ.

**ESC SO**Select Double-Wide Mode (one line)

---

## Format:

ASCII code: ESC SO

Decimal: 27 14

Hexadecimal: 1B 0E

## Comments:

Duplicates the SO command. This command is available in both draft and NLQ.

**DC4**Cancel Double-Wide Mode (one line)

---

## Format:

ASCII code: DC4

Decimal : 20

Hexadecimal: 14

## Comments:

Cancels one-line double-wide printing selected by SO or ESC SO, but not double-wide printing selected by ESC W or ESC !.

## Format:

ASCII code:	ESC	W	<i>n</i>
Decimal :	27	87	<i>n</i>
Hexadecimal:	1B	57	<i>n</i>

## Comments:

The following values can be used for *n*:

1: Mode is turned ON. (The ASCII codes 0 and 1 or the ASCII characters "0" and "1" can be used.)  
 0: Mode is turned OFF.

Double-wide mode doubles the width of all characters. This command is available in both draft and NLQ.

## Format:

ASCII code:	ESC	w	<i>n</i>
Decimal:	27	119	<i>n</i>
Hexadecimal:	1B	77	<i>n</i>

## Comments:

The following values can be used for *n*:

1: Mode is turned ON. (The ASCII codes 0 and 1 or the ASCII characters "0" and "1" can be used.)  
 0: Mode is turned OFF.

Double-hi mode doubles the height of all characters. Superscript, subscript, and condensed modes are not valid in the double-high mode. This command is available in both draft and NLQ.

## Print Enhancement

ESC E

Select Emphasized Mode

---

Format:

ASCII code:	ESC	E
Decimal :	27	69
Hexadecimal:	1B	45

Comments:

Makes text bolder by printing each dot twice, with the second dot slightly to the right of the first. This command is available in both draft and NLQ.

ESC F

Cancel Emphasized Mode

---

Format:

ASCII code:	ESC	F
Decimal:	27	70
Hexadecimal:	1B	46

Comments:

Cancels emphasized, the mode selected by ESC E. This command is available in both draft and NLQ.

ESC G

Select Double-Strike Mode

---

Format:

ASCII code:	ESC	G
Decimal:	27	71
Hexadecimal:	1B	47

Comments:

Makes text bolder by printing each line twice, with the second printing slightly below the first. Double-strike is not available in NLQ mode.

## Format:

ASCII code:	ESC	H
Decimal :	27	72
Hexadecimal:	1B	48

## Comments:

Turns off the double-strike mode selected by ESC G.

## ESC S 0

## Select Superscript Mode

## Format:

ASCII code:	ESC	S	NUL
Decimal:	27	83	0
Hexadecimal:	1B	53	00

## Comments:

Prints characters about two-thirds of the normal height in the upper part of the character space. The ASCII code 0 or the character “0” can be used in this command. It is cancelled with ESC T. This command is available in both draft and NLQ. It cannot be combined with double-high.

## ESC S 1

## Select Subscript Mode

## Format:

ASCII code:	ESC	S	SOH
Decimal :	27	83	1
Hexadecimal:	1B	53	01

## Comments:

Prints characters about two-thirds of the normal height in the lower part of the character space. The ASCII code 1 or the *character* “1” can be used in this command. It is cancelled with ESC T. This command is available in both draft and NLQ. It cannot be combined with double-high.

## Format:

ASCII code:	ESC	T
Decimal :	27	84
Hexadecimal:	1B	54

## Comments:

Cancels either superscript or subscript.

## Format :

ASCII code:	ESC	-	<i>n</i>
Decimal:	27	45	<i>n</i>
Hexadecimal:	1B	2D	<i>n</i>

## Comments:

The following values can be used for *n*:

1: Mode is turned ON. (The ASCII *codes* 0 and 1 or the ASCII *characters* "0" and "1" can be used.)  
 0: Mode is turned OFF.

This mode provides continuous underlining, including spaces. This command is available in both draft and NLQ.

# Word Processing

ESC a

Select Justification

Format:

ASCII code:	ESC	<b>a</b>	n
Decimal:	27	<b>97</b>	n
Hexadecimal:	1B	61	n

Comments:

The following values can be used for *n*:

0: Selects left justification.

1: Selects centering.

2: Selects right justification.

3: Selects full justification.

The default setting is  $n = 0$ . Full justification ( $n = 3$ ) is performed when the buffer becomes full. The commands HT and BS are invalid except in  $n = 0$  mode. For  $n = 3$  there must be no carriage returns within a paragraph. This command is available in both draft and NLQ.

ESC SP (space)

Set Intercharacter Space

Format:

ASCII code:	ESC	SP	n
Decimal:	27	32	n
Hexadecimal:	1B	20	n

Comments:

Sets the amount of space added to the right of each character, in addition to the space already allowed in the design of the character. The number of units of space is equal to *n*, which should be from 0 to 127. Each unit of space is 1/120th of an inch. This command is available in both draft and NLQ.

## Character Sets

### ESC t

### Select Character Table

---

#### Format:

ASCII code:	ESC	t	n
Decimal:	27	116	n
Hexadecimal:	1B	74	n

#### Comments:

The following values can be used for n:

0: Selects italic character set.

1: Selects Epson Extended Graphics character set.

Selects the character table used by ASCII codes 128 through 255. Selecting Epson Extended Graphics does not disable italic printing. Italic printing can still be selected by ESC 4. Duplicates and overrides the function of DIP switch 1-3. Note that the value of n must equal 00 hex or 01 hex; the characters "0" and "1" cannot be used. See Appendix B for the character tables.

### ESC 4

### Select Italic Mode

---

#### Format:

ASCII code:	ESC	4
Decimal:	27	52
Hexadecimal:	1B	34

#### Comments:

Causes characters from the italic character set to be printed.

This command is valid even if the Epson Extended Graphics character set has been selected by ESC t or the DIP switch 1-3, but character graphics cannot be italicized. This command is available in both draft and NLQ.

## Format:

ASCII code:	ESC	5
Decimal :	27	53
Hexadecimal:	1B	35

## Comments:

Cancels the mode selected by ESC 4. This command is available in both draft and NLQ.

## ESC R

## Select an International Character Set

## Format:

ASCII code:	ESC	R	n
Decimal:	27	82	n
Hexadecimal:	1B	52	n

## Comments:

See the section on international character sets in Chapter 3 for full information on international character sets. The following values can be used for *n*:

0=USA	5 = Sweden	9 = Norway
1 = France	6 = Italy	10 = Denmark II
2 = Germany	7= Spain I	11 = Spain II
3=UK	8 = Japan	12 = Latin America
4 = Denmark I		

Overrides the DIP switch settings for international characters. This command is available in both draft and NLQ.

## User-Defined Characters

Note: See Chapter 4 for sample programs and full information on this topic.

---

### ESC & Define User-Defined Characters

---

Format:

ASCII code:	ESC	&	NUL	<i>n1</i>	<i>d2</i>	.	.	.	<i>dn</i>
Decimal:	27	38	0	<i>n1</i>	<i>d2</i>	.	.	.	<i>dn</i>
Hexadecimal:	1B	26	00	<i>n1</i>	<i>d2</i>	.	.	.	<i>dn</i>

Comments:

This command defines characters as described in Chapter 4. This command is not effective when DIP switch 1-1 is on.

---

### ESC : Copy ROM into RAM

---

Format:

ASCII code:	ESC	:	0	<i>n</i>	0
Decimal:	27	58	0	<i>n</i>	0
Hexadecimal:	1B	3A	00	<i>n</i>	00

Comments:

This command copies the characters in the ROM into RAM so that specific characters can be redefined. The following values can be used for *n*:

0: Roman

1: Sans Serif

This command is not effective when DIP switch 1-1 is on.

## Format:

ASCII code:	ESC	%	n
Decimal:	27	37	n
Hexadecimal:	1B	25	n

## Comments:

ESC & is required to define the character set. The following values can be used for *n*:

0: Selects the normal set.

1: Selects the user-defined set.

For NLQ characters, also send ESC x 1.

## Format:

ASCII code:	ESC	6
Decimal:	27	54
Hexadecimal:	1B	36

## Comments:

Enables the printing of codes 128 through 159 (decimal) as characters, not control codes. This allows the use of these characters for user-defined characters.

## Format:

ASCII code:	ESC	7
Decimal :	27	55
Hexadecimal:	1B	37

## Comments:

This code causes codes 128 through 159 to be treated as control codes. This is the default. See Appendix B.

---

ESC IPrintable Code Area Expansion

---

## Format:

ASCII code:	ESC	I	<i>n</i>
Decimal:	27	73	<i>n</i>
Hexadecimal:	1B	49	<i>n</i>

## Comments:

ASCII codes 0 to 31 and 128 to 159 are usually not printable. These codes become printable upon input of the ESC I code if  $n = 1$ , which allows the use of these codes for user-defined characters. If  $n = 0$ , this command returns 0 to 31 and 128 to 159 to non-printable codes.

# Graphics

Note: See Chapter 4 for sample graphics programs.

---

## ESC K Select Single-Density Graphics Mode

Format:

ASCII code:	ESC	K	n1	<i>td</i>
Decimal:	27	75	n1	n2
Hexadecimal:	1B	4B	n1	n2

Comments:

Turns on eight-pin single-density graphics mode (60 dots per inch).  
The total number of columns =  $n1 + (n2 \times 256)$ .

---

## ESC L Select Double-Density Graphics Mode

Format:

ASCII code:	ESC	L	n1	<i>n2</i>
Decimal:	27	76	n1	<i>n2</i>
Hexadecimal:	B	4C	n1	<i>n2</i>

Comments:

Turns on eight-pin low-speed double-density graphics mode (120 dots per inch). The total number of columns =  $n1 + (n2 \times 256)$ .

---

## ESC Y Select High-Speed Double-Density Graphics Mode

Format:

ASCII code:	ESC	Y	n1	n2
Decimal:	27	89	n1	<i>n2</i>
Hexadecimal:	1B	59	n1	n2

Comments:

Turns on eight-pin high-speed double-density graphics mode (120 dots per inch). The total number of columns =  $n1 + (n2 \times 256)$ .

## ESC Z

## Select Quadruple-Density Graphics Mode

## Format:

ASCII code:	ESC	Z	n1	n2
Decimal:	27	90	n1	n2
Hexadecimal:	1B	5A	n1	n2

## Comments:

Turns on eight-pin quadruple-density graphics mode (240 dots per inch). The total number of columns =  $n1 + (n2 \times 256)$ .

## ESC \*

## Select Graphics Mode

## Format:

ASCII code:	ESC	*	m	n1	n2
Decimal :	27	42	m	n1	n2
Hexadecimal:	1B	2A	m	n1	n2

## Comments:

Turns on graphics mode m. See the table below for details on the available modes. The total number of columns =  $n1 + (n2 \times 256)$ .

Option	Alternate Code	m	Horiz. density (dots/in.)
Single-density	ESC K	0	60
Double-density	ESC L	1	120
High-speed double-density*	ESC Y	2	120
Quadruple-density*	ESC Z	3	240
CRT I	none	4	80
Plotter (1:1)	none	5	72
CRT II	none	6	90
Double-density plotter	none	7	144

\*Adjacent dots cannot be printed in this mode

## Format:

ASCII code:	ESC	?	s	n
Decimal :	27	63	s	n
Hexadecimal:	1B	3F	s	n

## Comments:

Changes one graphics mode to another. The variable *s* is a character (K, L, Y or Z), which is reassigned to a mode *n* (0-7).

## Format:

ASCII code:	ESC	^	m	n1	n2
Decimal:	27	94	m	n1	n2
Hexadecimal:	1B	5E	m	n1	n2

## Comments:

Turns on 9-pin graphics mode. For this command the variable *m* defines density of print: 0 for single (60 dpi) and 1 for double (120 dpi). The total number of columns =  $n1 + (n2 \times 256)$ . This mode requires two data items for each column of print.

## IBM Emulation Mode Commands

The Epson mode and the IBM emulation mode share many of the same commands. Therefore, this part of the summary merely lists and does not describe the commands already described in the Epson mode command summary. The commands that are different are described in detail.

### Commands that Duplicate Epson Commands

#### Printer Operation

DC1, ESC U, BEL

#### Data Buffer Control

CR, CAN

#### Paper Feed Control

FF, ESC C, ESC C 0, ESC N, ESC 0, LF, ESC 0, ESC 1, ESC 3, VT, ESC B

#### Print Head Control

BS, HT

#### Print Size/Character Width

SI, ESC SI, SO, ESC SO, DC4, ESC W, ESC E, ESC F, ESC G, ESC H, ESC SO, ESC **S1**, ESC **T**, ESC –

#### Graphics

ESC K, ESC L, ESC Y, ESC Z

Note that IBM emulation mode graphics are the same as Epson mode graphics except that ESC \*, ESC ?, and ESC ^ are not available.

# Commands That Are Different from Epson Commands

## Printer Operation

### ESC Q3

Deselect Printer (FX-850)

---

#### Format:

ASCII code:	ESC	Q	3
Decimal:	27	81	3
Hexadecimal:	1B	51	03

#### Comments:

Places the printer in an off line state until the printer is turned off and back on or until it receives a DC1 code.

### ESC Q22

Deselect Printer (FX-1050)

---

#### Format:

ASCII code:	ESC	Q	22
Decimal :	27	81	22
Hexadecimal:	1B	51	16

#### Comments:

Places the printer in an off line state until the printer is turned off and back on or until it receives a DC1 code.

## Vertical Motion

### ESC A

Set  $n/72$ -inch Line Spacing

---

#### Format:

ASCII code:	ESC	A	$n$
Decimal:	27	65	$n$
Hexadecimal:	1B	41	$n$

#### Comments:

Sets the line spacing to  $n/72$  of an inch. This value is stored in memory until the printer receives the ESC 2 command to put it into effect. The value of  $n$  must be from 1 to 85.

## Format:

ASCII code:	ESC	2
Decimal:	27	50
Hexadecimal:	1B	32

## Comments:

Executes the line spacing stored in memory by ESC A. If no ESC A command has been sent, ESC 2 sets the line spacing to  $1/6$  of an inch. (The 2 is the *character* two and not ASCII code 2.)

## ESC J

Perform n/216-inch Line Feed

---

## Format:

ASCII code:	ESC	J	n
Decimal :	27	74	n
Hexadecimal:	1B	4A	n

## Comments:

Advances the paper by one line at a spacing of n/216 of an inch. The value of n must be from 0 to 255. This command produces an immediate line feed but does not affect subsequent line spacing. It does not produce a carriage return unless DIP switch 1-3 is OFF.

## ESC 4

Set Top of Form

---

## Format:

ASCII code:	ESC	4
Decimal :	27	52
Hexadecimal:	1B	34

## Comments:

Sets the current position as top of form.

## Format:

ASCII code:	ESC	5	n
Decimal :	27	53	n
Hexadecimal:	1B	35	n

## Comments:

The following values can be used for n:

1: Mode is turned ON.

0: Mode is turned OFF.

If the mode is on, the printer adds a line feed to each carriage return. If the mode is off, it does not. This command duplicates the function of DIP switch 2-4.

## Horizontal Motion

## ESC X

## Set Left and Right Margins

## Format :

ASCII code:	ESC	X	n1	n2
Decimal:	27	88	<i>n1</i>	<i>n2</i>
Hexadecimal:	1B	58	<i>n1</i>	<i>n2</i>

## Comments:

The left margin column is set to *n1* in the current pitch, ignoring double-wide, and the right margin column is set to *n2*. The minimum distance between the two margins is 1/2 inch. The first column is number 1, not number 0.

## Format:

ASCII code:	ESC	D	<i>n1</i>	<i>n2</i>	.	.	.	NUL
Decimal :	27	68	<i>n1</i>	<i>n2</i>	.	.	.	0
Hexadecimal:	1B	44	<i>n1</i>	<i>n2</i>	.	.	.	00

## Comments:

This command allows the setting of up to 32 horizontal tabs, which are entered as *n1*, *n2*, *n3*, etc. (in the range 1 to 137) with the NUL character terminating the command. The tab settings must be entered in ascending order. ESC D NUL clears all tabs. The settings on power up are every eight characters. The tab settings change if the character pitch is changed, except that double-wide has no effect on the tab positions.

## Format:

ASCII code:	ESC	R
Decimal:	27	82
Hexadecimal:	1B	52

## Comments:

Resets all vertical and horizontal tab settings (set by ESC B and ESC D) to their defaults.

## Overall Printing Style

ESC I

Select Font

---

Format:

ASCII code:	ESC	I	<i>n</i>
Decimal:	27	73	<i>n</i>
Hexadecimal:	1B	49	<i>n</i>

Comments:

Selects the font according to the value specified for *n*. The value for *n* can be any one of the following:

- 0: Draft quality 10 cpi font
- 1: Draft quality 12 cpi font
- 2: Near letter quality Sans Serif font
- 3: Near letter quality Roman font
- 4: Draft quality 10 cpi download font
- 5: Draft quality 12 cpi download font
- 6: Near letter quality 10 cpi download font
- 7: Near letter quality 12 cpi download font

## Print Size/Width/Enhancements

Four modes in the IBM emulation mode are incompatible with each other. These modes are 10 cpi, 12 cpi, condensed, and proportional. Therefore, if you select any one of these, you cancel all the others.

ESC :

Select 12 cpi

---

Format:

ASCII code:	ESC	.
Decimal:	27	58
Hexadecimal:	1B	3A

Comments:

Selects **12** characters per inch.

---

 Format:

ASCII code:	ESC	P	<i>n</i>
Decimal:	27	80	<i>n</i>
Hexadecimal:	1B	50	<i>n</i>

Comments:

The following values can be used for *n*:

1: Mode is turned ON. (The ASCII *codes 0* and *1* or the ASCII  
 0: Mode is turned OFF *characters "0"* and *"1"* can be used.)

The width of proportional characters varies from character to character. Therefore, a narrow letter like *i* receives less space than a wide letter like *W*. The proportional widths are given in the character tables, which appear in Appendix B. This command overrides condensed, 10 cpi, and 12 cpi.

---

 Format:

ASCII code:	DC2
Decimal:	18
Hexadecimal:	12

Comments:

Cancels condensed, 12 cpi, and proportional printing and selects 10 cpi printing. The command does not cancel double-wide.

Format:

ASCII code: ESC [ @ *n1 n2 m1 m2 m3 m4*  
 Decimal: 27 91 64 *n1 n2 m1 m2 m3 m4*  
 Hexadecimal: 1B 5B 40 *n1 n2 m1 m2 m3 m4*

Comments:

The following values must be used: *n1*=4, *n2*=0, *m1*=0, and *m2*=0. The value of *m3* affects both character height and line feed as shown below:

<i>m3</i>	Char height	Line feed
1	Standard	Unchanged
2	Double-high	Unchanged
16	Unchanged	Single
17	Standard	Single
18	Double-high	Single
32	Unchanged	Double
33	Standard	Double
34	Double-high	Double

The value of *m4* selects the width of the characters.

- 1: Standard
- 2: Double-wide

Format:

ASCII code: ESC \_ *n*  
 Decimal: 27 95 *n*  
 Hexadecimal: 1B 5F *n*

Comments:

The following values can be used for *n*:

- 1: Mode is turned ON.
- 0: Mode is turned OFF.

## Character Sets

---

### ESC 6 Select International Character Set

---

Format:

ASCII code:	ESC	6
Decimal:	27	54
Hexadecimal:	1B	36

Comments:

Selects the international character set (Table 2). See the character set tables in Appendix B.

---

### ESC 7 Select Standard Character Set

---

Format:

ASCII code:	ESC	7
Decimal:	27	55
Hexadecimal:	1B	37

Comments:

Selects the standard character set (Table 1) if the international character set (Table 2) has been previously selected. See the character set tables in Appendix B.

---

### ESC \ Print Characters from Symbol Set

---

Format:

ASCII code:	ESC	\	<i>n1</i>	<i>n2</i>	<i>data</i>
Decimal :	27	92	<i>n1</i>	<i>n2</i>	<i>data</i>
Hexadecimal:	1B	5C	<i>n1</i>	<i>n2</i>	<i>data</i>

Comments:

Prints a number of characters from the symbol set. The number of characters =  $n1 + (n2 \times 256)$ . See the character tables in Appendix B for the symbol set and for the codes to use for *data*.

## Format:

ASCII code:	ESC	^	c
Decimal :	27	94	c
Hexadecimal:	1B	5E	c

## Comments:

Prints a single character (c) from the symbol set. See the character tables in Appendix B for the symbol set and the codes to use for c.

## User-Defined Characters

ESC =

Define User-Defined Characters

## Format:

ASCII code:	ESC	=	<i>n1</i>	<i>n2</i>	.	.	.	<i>nk</i>
Decimal:	27	61	<i>n1</i>	<i>n2</i>	.	.	.	<i>nk</i>
Hexadecimal:	1B	3D	<i>n1</i>	<i>n2</i>	.	.	.	<i>nk</i>

## Comments:

If C is the total number of characters to be defined,

$$B = (C \times 13) + 2$$

$$n1 = B \text{ MOD } 256$$

$$n2 = \text{INT}(B/256)$$

$$n3 = 20 \text{ in all cases}$$

$$n4 = \text{the code of the first character to be defined}$$

$$n5 = 0 \text{ if the top 8 pins are used; } n5 = 128 \text{ for the bottom 8}$$

$$n6 = 0 \text{ in all cases}$$

*n7* through *nk* are the data numbers that define the characters, with 11 data numbers for each character

The data numbers for each character are determined as shown on the first grid for the Epson mode in the section on user-defined characters in Chapter 4. To print a user-defined character, you must use ESC I, which is described on page 8-46.

## Technical Specifications

Printer Specifications .....	A-2
Interface Specifications .....	A-5
Initialization .....	A-8

# Printer Specifications

## Printing

Print method: 9-pin impact dot matrix

Print speed:

Quality	Pitch	Characters/second/line
Draft	10	220
	12	264
NLQ	10	45
	12	54

Printing direction: Bidirectional logic-seeking for text  
unidirectional-for graphics

Line spacing: 1/6" or 1/8" or programmable in increments  
of 1/216th of an inch

Paper feed speed: Single sheet: 48 ms/line (3.6" per sec)  
Continuous: 53 ms/line (3.0" per sec)

## Printable **columns**:

Character pitch	Maximum printed characters	
	FX-850	FX-1050
10 pitch	80	136
10 pitch condensed	137	233
12 pitch	96	163
12 pitch condensed	160	272

**Buffer:** 8 Kbyte

Character fonts: Draft  
NLQ Epson Roman  
Epson Sans Serif

Characters: 96 standard ASCII character set  
 (including italic characters)  
 13 international character sets  
 Epson Extended Graphics characters set

Paper width:

Paper Sheet	FX-850	FX-1050
Single Sheet	7.2 to 10.1" (182-257 mm)	7.2 to 14.4" (182-366 mm)
Continuous	4 to 10" (101-254 mm)	4 to 16" (101-406.4 mm)
Envelopes	6.5" or 9.5"	6.5" or 9.5"
Labels	2.5" or 4.0"	2.5" or 4.0"

Paper Length: Single sheet  
 7.2 to 14.3 inches (182 to 364 mm)

Printable area:

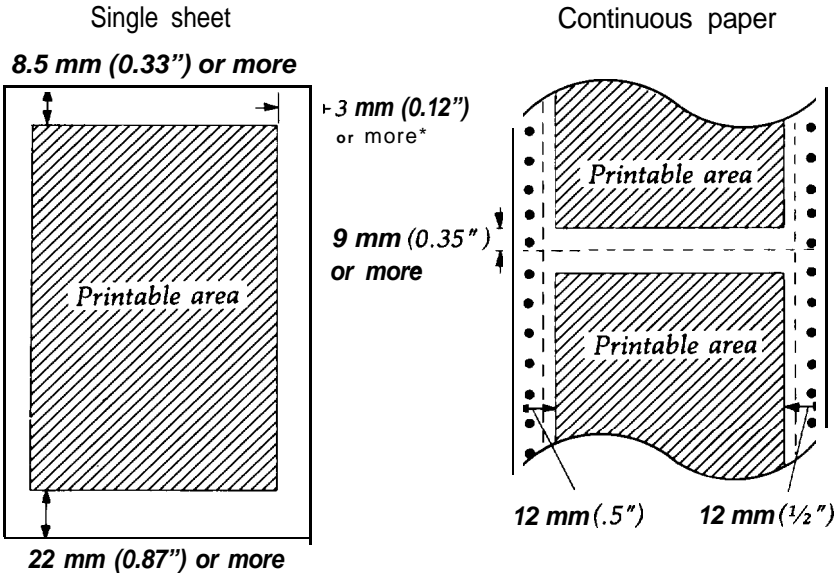

Number of copies: Up to 4 sheets including the original. Total thickness must not exceed 0.012" (0.32 mm)

Paper feeding methods:	Friction Push tractor Cut sheet feeder (optional) Pull tractor (optional)	
Ribbon	Cartridge ribbon, available in black only: #8750 (FX-850) #8755(M) (FX-1050)	
Life expectancy of ribbon:	3 million characters (14 dots/character)	
MCBF:	For all components excluding print head: 5 million lines	
MTBF:	FX 850 4000 power-on hours FX-1050 6000 power-on hours	
Print head life:	100 million characters (14 dots/character)	
Dimensions and weight:		
	FX-850	FX-1050
Height:	5.9"	5.9"
Width:	17.9"	24.8"
Depth:	14.2"	14.2"
Weight:	20.9 lbs	27.5 lbs
Voltage:	120 VAC $\pm$ 10%	
Power consumption:	120 watts maximum	
Frequency:	49.5 to 60.5 Hz	
Insulation resistance:	10M ohms between AC power line and chassis	
Dielectric strength (between AC line and chassis):	Can withstand 1.0 kV rms applied for one minute or 1250 VAC rms applied for one second.	
Temperature:	Operation: 40°F to 95°F (5°C to 35°C) Storage: -22°F to 140°F (-30°C to 60°C)	

Humidity: Operation: 10% to 80% (without condensation)  
Storage: 5% to 85% (without condensation)

Shock: Operation: Up to 1 G within 1 ms  
Storage: Up to 2 G within 1 ms

Vibration: Operation: Up to 0.25 G at up to 55 Hz  
Storage: Up to 0.50 G at up to 55 Hz

## Interface Specifications

Your printer is equipped with an 8-bit parallel interface. For specifications for optional interfaces, see the manuals provided with the optional interfaces.

I'm assignments for the parallel interface

Connector pin assignments and a description of their respective interface signals are shown in the following table.

Signal Pin	Return Pin	Signal	Direction	Description
1	19	<b>STROBE</b>	IN	STROBE pulse to read data in. Pulse width must be more than 0.5 microseconds at the receiving terminal.
2	20	DATA 1	IN	These signals represent information of the 1st to 8th bits of parallel data, respectively Each signal is at HIGH level when data is logical 1 and LOW when it is logical 0.
3	21	DATA 2	IN	
4	22	DATA 3	IN	
5	23	DATA 4	IN	
6	24	DATA 5	IN	
7	25	DATA 6	IN	
8	26	DATA 7	IN	
9	27	DATA 8	IN	
10	28	<b>ACKNLG</b>	OUT	About a 12-microsecond pulse. LOW indicates that data has been received and that the printer is ready to accept more data.

Signal Pin	Return Pin	Signal	Direction	Description
11	29	BUSY	OUT	A HIGH signal indicates that the printer cannot receive data. The signal goes HIGH in the following cases: 1) During data entry (ea. char. time) 2) During printing 3) When off line 4) During printer-error state.
12	30	PE	OUT	A HIGH signal indicates that the printer is out of paper.
13	—	—	—	Pulled up to 5 volts through 3.3K ohm resistance.
14	—	AUTO FEED XT	IN	When this signal is LOW, the paper is automatically fed 1 line after printing. (The signal level can be fixed to this by setting DIP switch 2-4 to ON.)
15	—	NC	—	Not used.
16	—	GND	—	Logic ground level.
17	—	CHASSIS GND	—	Printer's chassis ground, which is isolated from the logic ground.
18	—	NC	—	Not used.
19 - 30	—	GND	—	Twisted-pair return signal ground level.
31	—	INIT	IN	When this level becomes LOW, the printer controller is reset to its power-up state and the print buffer is cleared. This level is usually HIGH; its pulse width must be more than 50 microseconds at the receiving terminal.
32	—	ERROR	OUT	This level becomes LOW when the printer is: 1) in paper-out state 2) off line 3) in error state.
33	—	GND	—	Same as for Pins 19 - 30.
34	—	NC	—	Not used.
35	—	—	—	Pulled up to 5V through 3.3K ohm resistance.
36	—	SLCT IN	IN	The DC1/DC3 code is valid only when this signal is "HIGH". (Internal fixing can be carried out with Jumper J1. The level of this signal is factory-set to "LOW".)

- 1 The column heading "Direction" refers to the direction of signal flow as viewed from the printer.
- "Return" denotes the twisted-pair return, to be connected at signal ground level. For the interface wiring, be sure to use a twisted-pair cable for each signal and to complete the connection on the return side. These cables should be shielded and connected to the chassis of the host computer and the printer.
- 1 All interface conditions are based on TTL level. Both the rise and the fall times of each signal must be less than 0.2 microseconds.
- 1 Data transfer must be carried out by observing the ACKNLG or BUSY signal. Data transfer to this printer can be carried out only after receipt of the ACKNLG signal or when the level of the BUSY signal is LOW.

### Printing enabled/disabled signals and control conditions

The following table shows the relationship between printing being enabled or disabled, the on line/off line status, and the receipt of the data on/off control characters, DC1 or DC3.

ON LINE (Indicator on)	SLCT IN	DC1 /DC3 (Data on/off control)	ERROR	BUSY	ACKNLG	Printing (Disabled/ enabled)
on line	Low (J1/ interface)	DC1/DC3 (no effect)	High	High/Low	Pulsed ea. char.	Enabled (normal cond.)
on line	High	DC1 Recv'd	High	High/Low	Pulsed ea. char.	Enabled
on line	High	DC3 Recv'd	High	High/Low	Pulsed ea. char.	Disabled*
off line	High/Low (no effect)	DC1/DC3 (no effect)	Low	High	Not generated	Disabled

\*While printing is disabled, character data is being received and acknowledged so that the printer can look for another DC1 character, which would allow it to resume printing.

## Interface timing

The figure below shows the timing for the parallel interface.

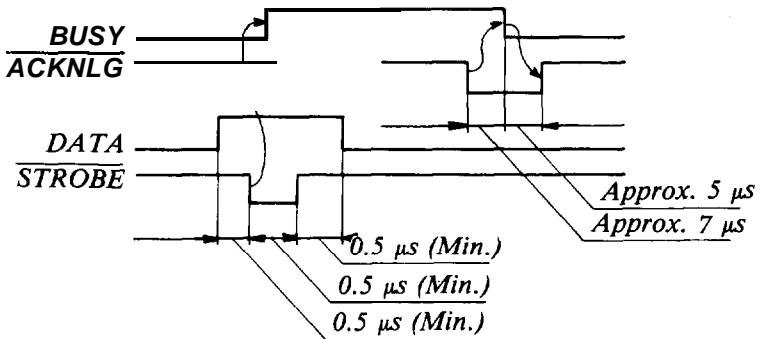

## Initialization

There are three ways that the printer can be initialized (returned to a fixed set of conditions).

- Hardware initialization
  - | When the power is turned on.
  - | When the printer receives an  $\overline{\text{INIT}}$  signal at the parallel interface (pin 31 goes LOW).
- Software initialization
  - | Software sends the ESC @ (initialize the printer) command.

## Default Settings

The table below shows the default conditions that become valid when the printer is initialized.

Item	Reset to:
Top of form position	Current paper position
Left and right margins	Cancelled
Line spacing	1/6-inch line spacing
Vertical tab position	Cleared
Horizontal tab positions	Every eight characters
VFU channel	Channel 0
Font selection	Reset to the current SelecType setting
CPI	Reset to the current SelecType setting
Justification	Left Justification
Special printing effects	Cancelled

In addition, the data buffer is cleared when the printer is initialized by turning on the power or by an INIT signal.

Note: The userdefined character set is not cleared when the printer is initialized.

## Tables

Proportional Width Table ..... B-2

Character Tables ..... B-6

## Proportional Width Table

This table lists the widths of your printer's proportional characters. The values given are in 120ths of an inch. (For example, a value of 12 is 12/120ths of an inch.) You may need to enter these widths into a special table for your word processing program so it can calculate the number of proportional characters that will fit on a line.

The characters with no code indicated are international characters or graphics. See the table in the section on international character sets in Chapter 3 for the relevant codes for the international characters. Also, see the descriptions of the ESC R and ESC t commands in the Command Summary for information on how to use these characters.

The following width table shows each code (hexadecimal), its character, and its width. If there are two numbers in the width column, the second one is for the italic character.

Code	CHR	Width
<b>20</b>		<b>12112</b>
<b>21</b>	!	5/10
<b>22</b>	"	8/10
<b>23</b>	#	12/12
<b>24</b>	\$	12/11
<b>25</b>	%	12/12
<b>26</b>	&	12/12
<b>27</b>	(	5/5
<b>28</b>	)	6/8
<b>29</b>		<b>618</b>
<b>2A</b>	*	12/12
<b>2B</b>	+	12/12
<b>2c</b>		7/8
<b>2D</b>	-	12/12
<b>2E</b>	.	<b>617</b>
<b>2F</b>	/	10/10

Code	CHR	Width
<b>30</b>	()	12/12
<b>31</b>	1	8/9
<b>32</b>	2	12/12
<b>33</b>	3	<b>12112</b>
<b>34</b>	4	12/12
<b>35</b>	5	12/12
<b>36</b>	6	12/11
<b>37</b>	7	12/12
<b>38</b>	8	<b>12112</b>
<b>39</b>	9	12/11
<b>3A</b>		<b>618</b>
<b>3B</b>	,	6/9
<b>3c</b>	<	10/10
<b>3D</b>	=	12/11
<b>3E</b>	>	10/9
<b>3F</b>	?	12/11

Code	CHR	Width
40	@	12/12
41	A	12/12
42	B	12/12
43	C	12/12
44	D	12/12
45	E	12/12
46	F	12/12
47	G	12/12
48	H	12/12
49	I	8/10
4A	J	11/12
4B	K	12/12
4C	L	12/10
4D	M	12/12
4E	N	12/12
4F	O	12/12
	P	12/12
5J	Q	12/12
52	R	12/12
	S	12/12
54	T	12/12
55	U	12/12
56	V	12/11
57	W	12/12
58	X	10/12
59	Y	12/12
5A	Z	10/12
5B	[	8/11
5C	\	10/7
5D	]	8/11
5E	^	12/10
5F	~	12/12
60	`	5/5
	a	12/11
62	b	11/11
63	c	11/11

Code	CHR	Width
64	d	11/12
65	e	12/11
66	g	10/12
67	h	11/11
68		11/11
69	j	8/9
6A	k	9/10
6B		10/11
6C	l	8/9
6D	m	12/11
6E	n	11/10
6F	o	12/11
70	p	11/11
71	q	11/11
72	s	11/10
73	t	12/11
74		11/10
75	u	12/11
76	v	12/10
77	w	12/12
78	x	10/12
79	y	12/11
7A	z	10/12
7B	{	9/10
7C		5/9
7D	}	9/10
7E		12/12
	Ç	12/12
	ü	11/12
	é	12/11
	â	12/12
	ä	12/11
	å	12/11
	ç	11/11
	ê	12/12

Code	CHR	Width
	ë	12/11
	è	12/11
	ï	8/10
	î	10/11
	ì	8/8
	Ä	12/12
	Å	12/12
	É	12/12
	æ	12/12
	Æ	12/12
	ô	10/12
	ö	10/11
	ò	10/11
	û	11/11
	ù	11/11
	ÿ	12/11
	Ö	12/12
	Ü	12/12
	Φ	11/11
	£	12/12
	¥	12/12
	℞	12/12
	f	11/12
	á	12/11
	í	8/10
	ó	10/12
	û	11/11
	ñ	11/12
	Ñ	12/12
	â	12/11
	ó	12/12
	ì	12/11
	í	12/12
	î	12/12
	ï	12/12
	¼	12/12
	½	12/12
	¾	12/12
	ı	5/10

Code	CHR	Width
	«	12/12
	»	12/12
B0	⋮	12
B1	⋮	12
B2	⋮	12
B3	⋮	12
B4	⋮	12
B5	⋮	12
B6	⋮	12
B7	⋮	12
B8	⋮	12
B9	⋮	12
BA	⋮	12
BB	⋮	12
BC	⋮	12
BD	⋮	12
BE	⋮	12
BF	⋮	12
C0	⋮	12
C1	⋮	12
C2	⋮	12
C3	⋮	12
C4	⋮	12
C5	⋮	12
C6	⋮	12
C7	⋮	12
C8	⋮	12
C9	⋮	12
CA	⋮	12
CB	⋮	12
CC	⋮	12
CD	⋮	12
CE	⋮	12
CF	⋮	12
D0	⋮	12
D1	⋮	12
D2	⋮	12

Code	CHR	Width
D3	⋈	12
D4	⋉	12
D5	⋊	12
D6	⋋	12
D7	⋌	12
D8	⋍	12
D9	⋎	12
DA	⋏	12
DB	■	12
DC	▬	12
DD	▮	12
DE	▯	12
DF	▰	12
E0	α	12/12
E1	β	11/11
E2	Γ	10/12
E3	π	12/12
E4	Σ	10/12
E5	σ	11/12
E6	μ	11/12
E7	τ	12/12
E8	ϕ	10/12
E9	θ	12/12
EA	Ω	12/12
EB	δ	12/11
EC	θ	12/12
ED	ϕ	12/12
EE	ε	10/10
EF	∩	10/12
F0	≡	11
F1	±	11
F2	∨	11
F3	∩	11
F4	↵	11
F5	↶	11
F6	⋈	11
F7	⋉	11

Code	CHR	Width
F8	◦	11
F9	•	11
FA	•	11
FB	√	11
FC	n	11
FD	z	11
FE	■	11
	◦	8/8
	α	
	β	11/11
	∅	12/12
	∅	12/11
	::	8/9
	§	10/12

## Character Tables

These character tables are selected by setting DIP switch 1-3 or using the ESC t software command. For the Epson Extended Graphics character table, use of the ESC 6 or ESC 7 software command lets you select whether to print hex codes 80 to 9F as characters (ESC 6) or control codes (ESC 7).

### Italic Character Table

CODE	0	1	2	3	4	5	6	7	8	9	A	B	C	D	E	F
0			0	@	P	`	p				0	@	P	`	p	
1		!	1	A	Q	a	q				!	1	A	Q	a	q
2		"	2	B	R	b	r				"	2	B	R	b	r
3		#	3	C	S	c	s				#	3	C	S	c	s
4		\$	4	D	T	d	t				\$	4	D	T	d	t
5		%	5	E	U	e	u				%	5	E	U	e	u
6		&	6	F	V	f	v				&	6	F	V	f	v
7		'	7	G	W	g	w				'	7	G	W	g	w
8		(	8	H	X	h	x				(	8	H	X	h	x
9		)	9	I	Y	i	y				)	9	I	Y	i	y
A		*	:	J	Z	j	z				*	:	J	Z	j	z
B		+	;	K	[	k	{				+	;	K	[	k	{
C		,	<	L	\	l	!				,	<	L	\	l	!
D		-	=	M	]	m	}				-	=	M	]	m	}
E		.	>	N	^	n	~				.	>	N	^	n	~
F		/	?	O	_	o					/	?	O	_	o	

# Epson Extended Graphics Character Table

CODE	0	1	2	3	4	5	6	7	8	9	A	B	C	D	E	F
0			0	@	P	`	p	Ç	É	á	▤	⊥	⊥	α	≡	
1		!	1	A	Q	a	q	ü	æ	í	▥	⊥	⊥	β	±	
2		"	2	B	R	b	r	é	Æ	ó	▧	⊥	⊥	Γ	≥	
3		#	3	C	S	c	s	â	ô	ú		⊥	⊥	π	≤	
4		\$	4	D	T	d	t	ä	ö	ñ	⊥	-	⊥	Σ	∫	
5	§	%	5	E	U	e	u	à	ò	Ñ	⊥	⊥	⊥	F	σ	∫
6		&	6	F	V	f	v	ã	û	ã	⊥	⊥	⊥	π	μ	÷
7		'	7	G	W	g	w	ç	ù	ó	⊥	⊥	⊥	⊥	τ	≈
8		(	8	H	X	h	x	ê	ý	¿	⊥	⊥	⊥	⊥	Φ	°
9		)	9	I	Y	i	y	ë	Ö	¬	⊥	⊥	⊥	⊥	Θ	•
A		*	:	J	Z	j	z	è	Ü	¬	⊥	⊥	⊥	⊥	Ω	•
B		+	;	K	[	k	{	ï	Φ	½	⊥	⊥	⊥	■	δ	√
C		,	<	L	\	l		î	£	¼	⊥	⊥	⊥	■	∞	³
D		-	=	M	]	m	}	ï	¥	;	⊥	⊥	⊥	■	∅	²
E		.	>	N	^	n	~	Ä	℞	«	⊥	⊥	⊥	■	€	•
F		/	?	O	_	o		Å	f	»	⊥	⊥	⊥	■	∩	

---

# Glossary

Note that these definitions apply specifically to printers. If a word is italicized, see that topic for more information.

application program

A program that helps you carry out a particular task, such as word processing or financial planning.

ASCII

American Standard Code for Information Interchange. A standardized coding system for assigning numerical codes to letters and symbols.

automatic line feed

When this feature is turned on using a DIP switch, each carriage return code (CR) is automatically accompanied by a line feed (LF) code.

baud rate

A measure of the speed of data transmission. Usually equivalent to bits per second.

bidirectional printing

Printing in which the print head goes from left to right only on every other line. On the other lines, it goes from right to left. This increases the speed of printing because the head prints in both directions.

binary

See *number systems*.

bit

A binary digit (0 or 1), which is the smallest unit of information used by a printer or computer. See also *number systems*.

buffer

See *memory*.

byte

A unit of information consisting of eight bits.

carriage return

The control code that returns the print position to the left margin. When issued together with a line feed, the print position moves to the left margin of the next line. In bidirectional printing, the print head may not actually move to the left margin.

characters per inch (cpi)

A measure of the size of text characters, often referred to as pitch. 10 cpi (also called pica) is often the standard or default setting.

character set

A collection of letters, numbers, and symbols that provides you with the characters used in a particular language.

condensed

Printing in which each character is approximately 60% of the width of standard characters. Useful for fitting wide tables or spreadsheets onto the paper.

continuous paper

Paper that has sprocket-feed holes on each side, is perforated between pages, and comes in a folded stack. Also called fanfold paper.

control code

Besides the codes for printable characters, the ASCII standard also includes 33 other codes called control codes. These control codes perform such functions as sounding the beeper and performing a carriage return or line feed.

cut sheet feeder (CSF)

An optional, detachable device that automatically feeds single sheets of paper into the printer.

data dump

A troubleshooting feature. When the printer is in data dump mode, each code that it receives is printed in hexadecimal notation as well as the ASCII codes that stand for the characters. Sometimes called hex dump.

decimal

See number *systems*.

### default

A value or setting that takes effect when the equipment is turned on, reset, or initialized.

### DIP switches

Small switches in a printer that control various printer functions and set the default status of the printer when it is turned on or initialized. DIP stands for Dual In-line Package.

### dot graphics

A graphic design formed by patterns of dots.

### dot matrix

A method of printing in which each letter or symbol is formed by a pattern (matrix) of individual dots.

### double-high printing

Printing in which each character is twice as high as normal.

### double-strike printing

A way of producing bolder characters. Each character is printed twice; the second time, the dots are printed slightly below the original dots. Can only be used in draft mode.

### double-wide printing

A print width in which each character is twice as wide as normal characters. (Double-wide was formerly known as expanded.)

### draft

One of two print qualities available on your printer. Draft uses a minimum number of dots per character for high-speed printing. See also near *letter quality*.

### emphasized printing

A way of producing darker characters. Each character is printed twice, with the second slightly to the right of the first.

### Epson Extended Graphics

The Epson Extended Graphics character table contains international accented characters, Greek characters, and character graphics for printing lines, comers, and shaded areas.

ESC (escape)

A special control code used to begin most printer commands.

ESC/P

Abbreviation for Epson Standard Code for Printers. The system of commands lets you control your printer using your computer's software. It is standard for all Epson printers and supported by most applications software for personal computers.

font

A style of type designated by a family name.

form

In printer terminology, a form is normally the equivalent of a page.

form feed

A control code and a control panel button that advances the paper to the top of the next form.

hexadecimal (hex)

*See number systems.*

initialize

To establish the initial default status of the printer by turning the printer on or sending an INIT signal.

interface

The connection between the computer and the printer. A parallel interface transmits data one character or code at a time, and a serial interface transmits data one bit at a time.

italic

A typestyle in which the characters slant. *This sentence is italicized.*

near letter quality (NLQ)

One of two print qualities available on your printer. Near letter quality reduces the print speed and increases the number of dots per character to increase the print quality. See also *draft*.

line feed

A control code and a control panel button that advances the paper one line space.

memory

The printer, like a computer, has a memory. When you print a file from a computer, the contents of the file are transferred quickly from the computer's memory to the printer's memory. The printer then prints information from its own memory at a much slower rate. This way of printing frees the computer to do other work while the printer is still working. The printer memory is sometimes called the buffer.

micro-adjustment

A feature that adjusts the paper loading and tear-off positions.

number systems

Three number systems are commonly used with printers:

decimal is base 10 and uses the digits 0, 1, 2, 3, 4, 5, 6, 7, 8, and 9. (This is the most familiar system.)

hexadecimal (hex) is base 16 and uses the digits 0, 1, 2, 3, 4, 5, 6, 7, 8, 9, A, B, C, D, E, and F. This is frequently used by programmers. Any decimal number between 0 and 255 can be expressed by a two-digit hex number.

binary is base 2 and uses only the digits 0 and 1. All information in computer systems is handled in binary form to represent electrical signals that are on or off. A binary digit is often called a bit; any decimal number between 0 and 255 can be expressed by an eight-bit binary number.

on line

When the printer is on line, it can communicate with the computer connected to it,

paper-out sensor

A small switch behind the platen that sends a signal when it is not in contact with paper, causing the PAPER OUT light to go on.

paper tension unit

The part of the printer that fits on top of the platen to ensure proper paper feed tension.

parallel interface

*See interface.*

**parity**

Parity is a method for a computer and printer to check the reliability of data transmission.

**pitch**

Indicates the number of characters per inch (cpi). The standard is **10** pitch.

**platen**

The black roller that provides a backing for the printing.

**print quality**

Your printer has two types of print quality: draft and near letter quality (NLQ). Draft is for high-speed, draft-quality jobs; NLQ is for final, polished documents.

**proportional printing**

Printing in which the width of the character varies from character to character. For example, an uppercase W receives much more space than a lowercase i. The result looks more like a typeset book than a typewritten draft.

**push tractor**

The built-in device that feeds continuous paper through the printer.

**RAM**

Random Access Memory. The portion of the printer's memory used as a buffer and for storing user-defined characters. All data stored in RAM is lost when the printer is turned off.

**reset**

To return a printer to its defaults, by either a command, an INIT signal, or by turning the printer off and on.

**self test**

A method of checking the operation of the printer. When the self test is run, the printer prints out its current DIP switch settings and the characters that are stored in its ROM.

**serial interface**

*See interface.*

top of form position

The position on the paper that the printer recognizes as the first printable line. For single sheets, this is the position to which the paper is automatically loaded. For continuous paper, this position can be set to the current paper position by turning the printer off and on.

user-defined characters

Characters that are defined and stored in the printer by the user. Also known as download characters.

short tear-off

A feature that automatically feeds the perforation of continuous paper to the tear-off position and then feeds the paper back to the loading position. This position can be adjusted by using the micro-adjustment feature.

---

# Index

Command descriptions are not indexed here. For page references for specific commands, see Chapter 8 or the Quick Reference card.

## A

Application programs, 4-2 -5

Automatic line feed, 3-10

## B

Built-in character fonts, 3-11 -12

Buttons, 3-3

## C

Characters per inch, 3-12

Character size, 3-13 -14

Character tables, 3-7 -8

using, 4-7

Computer, connecting to the printer,

1-18 -20

Computer-printer communication,

4-5 -7

Condensed mode, 3-12

Control panel

buttons, 3-3

data dump mode, 3-5, 6-5 -6

lights, 3-2

operation, 3-2 -5

SelecType, 3-4

self test, 1-12 -18, 3-5

Cut sheet feeder, 7-2 -14

loading paper, 7-5 -7

installing, 7-2 -4

mode, 3-10, 7-11

setting page length, 7-9 -11

software operation, 7-10

testing the printer, 7-11 -12

using, 7-8 -9

## D

Data dump mode, 3-5, 6-5 -6

Default settings, A-9

DIP switches

function descriptions, 3-6 -10

function tables, 3-6 -9

selecting character tables, 3-7 -8

selecting international character sets, 3-9

selecting fonts, 3-10 -11

setting, 3-5 -6

Dot graphics mode, 4-8 -19

Double-strike printing, 3-14 -15

## E

Emphasized printing, 3-14 -15

Epson Extended Graphics, 3-7 -8,

B-7

## F

Fonts

Built-in character fonts, 3-11

Draft, 3-10 -11

Roman, 3-11

Sans serif, 3-11

Selecting with DIP switches, 3-11 -12

Selecting with SelecType, 3-11 -12

Form feed button, 3-3

## G

- Graphics, 4-8 -19
- Graphics mode command, 4-11 -12

## I

- Indicator lights, 3-2 -3
- Interface boards, 7-22 -33
  - compatibility, 7-23
  - installation, 7-23 -33
  - specifications, A-5
- International character sets, 3-7, 3-9
- Italic character table, 3-8, B-6
- Italic printing, 3-15

## L

- Lights, 3-2 -3
- Line feed button, 3-3
- Load/eject button, 3-3
- Loading paper
  - adjusting loading position, 2-14
  - adjusting paper thickness lever, 2-17 -18
  - continuous paper, 2-4 -8
  - envelopes, 2-19
  - labels, 2-19
  - multi-part forms, 2-18 -19
  - positioning continuous paper, 2-9
  - single sheets, 2-2 -4
  - switching between continuous and single sheets, 2-10 -14
  - using cut sheet feeder, 7-5 -7

## M

- Maintaining the printer, 5-1 -8
- Master Select, 3-15 -17
- Micro-adjustment, 2-14 -15, 3-5
- Moving the printer, 5-6 -8

## O

- On line light, 3-2
- On line button, 3-3
- Options, 2, 7-1 -33
  - cut sheet feeder, 7-2 -14, also see Cut sheet feeder
  - interface boards, 7-22 -33, also see Interface boards
  - pull tractor, 7-15 -22 also see Pull tractor

## P

- Page length, 3-9
  - using cut sheet feeder, 7-9 -11
- Paper
  - adjusting loading position, 2-14
  - adjusting paper thickness lever, 2-17 -18
  - positioning continuous paper, 2-9
    - using continuous paper, 2-4 -8
    - using multi-part forms, 2-18 -19
    - using single sheets, 2-2 -4
    - using special paper, 2-17 -19
- Paper guide
  - attaching, 1-11 -12, 2-4
  - attaching for continuous paper, 2-4
- Paper out light, 3-2
- Paper thickness lever
  - adjusting, 2-17 -18
  - paper thickness table, 2-18
- Parallel interface, connecting, 1-18 -20, also see Interface boards
- Pin labels, 4-10 -11
- Platen knob, installing, 1-6 -7
- Print head, 4-9 -10
- Printer
  - assembling, 1-6 -12

- cleaning, 5-2 -3
- connecting to a computer,  
1-18 -20
- default settings, A-9
- options, 2, 7-1 -33
- plugging in, 1-13
- specifications, A-2 -10
- testing, 1-12 -18, 7-11 -12
- transporting, 5-6 -8
- unpacking, 1-2

Power light, 3-2

Proportional width table, B-2

Pull tractor

- installing, 7-15 -21

- removing, 7-21 -22

## R

Ready light, 3-2

Ribbon cartridge

- installing, 1-8 -10

- replacing, 5-3 -6

## S

Selecting tpestyles, 3-15 -17

SelectType

- lights, 3-4

- selecting fonts, 3-11 -12

Self test, 1-12 -18, 3-5

- using cut sheet feeder, 7-12 -13

Serial interface, *see Interface boards*

Short tear-off, 2-15 -17, 3-8

Skip over perforation, 3-10

Specifications, A-2 -10

Subscripts, 3-15

Superscripts, 3-15

Technical specifications, A-2 -10

Testing the printer, 1-12 -17

- using cut sheet feeder, 7-12 -13

Troubleshooting, 6-1 -6

## Typesyles

- built-in character fonts, 3-11

- selecting with DIP switches,  
3-10 -12

- selecting with Master Select,  
3-15 -17

- selecting with SelecType,  
3-11 -12

Underlining, 3-15

Unpacking the printer, 1-2

User-defined characters, 4-19 -26

**EPSON®**

**F X - 8 5 0 / 1 0 5 0**

Quick Reference

This section lists all the FX commands. The numbers in the columns on the right are the page numbers in Chapter 8 where a complete description of the command can be found. If the Epson and IBM emulation mode page numbers are the same, the command is the same in both modes and is described only in the Epson mode section.

Epson IBM  
ESC/P ESC/P  
Mode Mode

### Printer Operation/Data Control

Code	Dec	Hex	Function	Page	Page
ESC @	64	40	Initialize Printer	8-8	
DC1	17	11	Select Printer	8-8	8-8
DC3	19	13	Deselect Printer	8-9	
ESC s	115	73	Turn Half-Speed Mode On/Off	8-9	
ESC <	60	3C	Select Unidirectional Mode (one line)	8-9	
ESC U	85	55	Turn Unidirectional Mode On/Off	8-10	8-10
ESC 8	56	38	Disable Paper-Out Sensor	8-10	
ESC 9	57	39	Enable Paper-Out Sensor	8-10	
ESC EM	25	19	Turn Cut Sheet Feeder On/Off	8-11	
ESC =	61	3D	Set MSB to 0	8-11	
ESC >	62	3E	Set MSB to 1	8-12	
ESC #	35	23	Cancel MSB Control	8-12	
BEL	7	07	Beeper	8-12	8-12
CR	13	0D	Carriage Return	8-13	8-13
CAN	24	18	Cancel Line	8-13	8-13
DEL	127	7F	Delete Character	8-13	

### Vertical Motion/Horizontal Motion

FF	12	0C	Form Feed	8-14	8-14
ESC C	67	43	Set Page Length in Lines	8-14	8-14
ESC C 0	67	43	Set Page Length in Inches	8-14	8-14
ESC N	78	4E	Set Skip Over Perforation	8-15	8-15
ESC O	79	4F	Cancel Skip Over Perforation	8-15	8-15
LF	10	0A	Line Feed	8-15	8-15
ESC 0	48	30	Select 1/8-inch Line Spacing	8-16	8-16
ESC 1	49	31	Select 7/72-inch Line Spacing	8-16	
ESC 2	50	32	Select 1/6-inch Line Spacing	8-16	
ESC 3	51	33	Select $n/216$ -inch Line Spacing	8-17	8-17
ESC A	65	41	Select $n/72$ -inch Line Spacing	8-17	
ESC J	74	4A	Perform $n/216$ -inch Line Feed	8-17	8-43
VT	11	0B	Tab Vertically	8-18	8-18
ESC B	66	42	Set Vertical Tabs	8-18	8-18
ESC b	98	62	Set Vertical Tabs in Channels	8-18	
ESC /	47	2F	Set Vertical Tab Channel	8-19	
ESC I	108	6C	Set Left Margin	8-19	
ESC Q	81	51	Set Right Margin	8-20	
BS	8	08	Backspace	8-20	8-20
ESC \$	36	24	Set Absolute Print Position	8-21	
ESC \	92	5C	Set Relative Print Position	8-21	
HT	9	09	Tab Horizontally	8-22	8-22
ESC D	68	44	Set Horizontal Tabs	8-22	8-45

## Overall Printing Style/Print Size

Code	Dec	Hex	Function	Page	Page
ESC x	120	78	Select NLQ or Draft	8-23	
ESC k	107	6B	Select NLQ Font	8-23	
ESC !	33	21	Master Select	8-24	
ESC P	80	50	Select 10 cpi	8-24	
ESC M	77	4D	Select 12 cpi	8-25	
ESC p	112	70	Turn Proportional Mode On/Off	8-25	
SI (ESC SI)	15	0F	Select Condensed Mode	8-26	8-26
DC2	18	12	Cancel Condensed Mode	8-26	
SO (ESC SO)	14	0E	Select Double-Wide Mode (one line)	8-27	8-27
DC4	20	14	Cancel Double-Wide Mode (one line)	8-27	8-27
ESC W	87	57	Turn Double-Wide Mode On/Off	8-28	8-28
ESC w	119	77	Turn Double-High Mode On/Off	8-28	

## Print Enhancement/Word Processing

ESC E	69	45	Select Emphasized Mode	8-29	8-29
ESC F	70	46	Cancel Emphasized Mode	8-29	8-29
ESC G	71	47	Select Double-Strike Mode	8-29	8-29
ESC H	72	48	Cancel Double-Strike Mode	8-30	8-30
ESC S0	83	53	Select Superscript Mode	8-30	8-30
ESC S1	83	53	Select Subscript Mode	8-30	8-30
ESC T	84	54	Cancel Superscript/Subscript	8-31	8-31
ESC -	45	2D	Turn Underlining On/Off	8-31	8-31
ESC a	97	61	Select Justification	8-32	
ESC SP (space)	32	20	Set Intercharacter Space	8-32	

## Character Sets

ESC t	116	74	Select Character Table	6-33	
ESC 4	52	34	Select Italic Mode	6-33	
ESC 5	53	35	Cancel Italic Mode	8-34	
ESC R	82	52	International Character Set	8-34	

## User-Defined Characters/Graphics

ESC &	38	26	Define User-Defined Characters	8-35	
ESC :	58	3A	Copy ROM to RAM	8-35	
ESC %	37	25	Select User-Defined Set	8-36	
ESC 6	54	36	Printable Code Area Expansion	8-36	
ESC 7	55	37	Cancel ESC 6	8-37	
ESC I	73	49	Printable Code Area Expansion	8-37	
ESC K	75	4B	Select Single-Density Graphics Mode	8-38	8-38
ESC L	76	4C	Select Double-Density Graphics Mode	8-38	8-38
ESC Y	89	59	Select High-Speed Double-Density Graphics	8-38	8-38
ESC Z	90	5A	Select Quadruple-Density Graphics Mode	8-39	8-39
ESC *	42	2A	Select Graphics Mode	8-39	
ESC ?	63	3F	Reassign Graphics Mode	8-40	
ESC ^	94	5E	Select S-Pin Graphics Mode	8-40	

## Commands for IBM Emulation Mode Only

Code	Dec	Hex	Function	Page
ESC Q3	81	51	Deselect Printer (FX-850)	8-42
ESC Q22	81	51	Deselect Printer (FX-1050)	8-42
ESC A	65	41	Set <i>n</i> /72-inch Line Spacing	8-42
ESC 2	50	32	Select Programmable Line Spacing	8-43
ESC J	74	4A	Perform <i>n</i> /216-inch Line Feed	8-43
ESC 4	52	34	Set Top of Form	8-43
ESC 5	53	35	Turn Automatic Line Feed On/Off	8-44
ESC X	88	58	Set Left and Right Margins	8-44
ESC D	68	44	Set Horizontal Tabs	8-45
ESC R	82	52	Restore Default Tab Settings	8-45
ESC I	73	49	Select Font	8-46
ESC :	58	3A	Select 12 cpi	8-46
ESC P	80	50	Turn Proportional Mode On/Off	8-47
DC2	18	12	Cancel Condensed/12 cpi/Proportional	8-47
ESC [@	91	5B	Select Double-High/Double-Wide Printing	8-48
ESC _	95	5F	Turn Overscore On/Off	8-48
ESC 6	54	36	Select International Character Set	8-49
ESC 7	55	37	Select Standard Character Set	8-49
ESC \	92	5C	Print Character from Symbol Set	8-49
ESC ^	94	5E	Print One Character from Symbol Set	8-50
ESC =	61	3D	Define User-Defined Characters	8-50

## DIP Switch Functions

Switch	Description	ON	OFF
1-1	Default character set	User-defined	ROM
1-2	Zero character	Slashed	Not slashed
1-3	Character table	Graphic	Italic
1-4	Printer mode	IBM emulation	Epson ESC/P
1-5	Short tear-off mode	OFF <b>DISABLED</b>	ON <b>ENABLED</b>
1-6	International character set	See table below	
1-7			
1-8			
2-1	Page length	12 inch	11 inch
2-2	Cut sheet feeder mode	On	Off
2-3	1-inch skip over perforation	On	Off
2-4	Automatic line feed	On	Off

## International character sets

Country	SW1-6	SW1-7	SW1-8
USA	On	On	On
France	On	On	Off
Germany	On	Off	On
UK	On	Off	Off
Denmark	Off	On	On
Sweden	Off	On	Off
Italy	Off	Off	On
Spain	Off	Off	Off

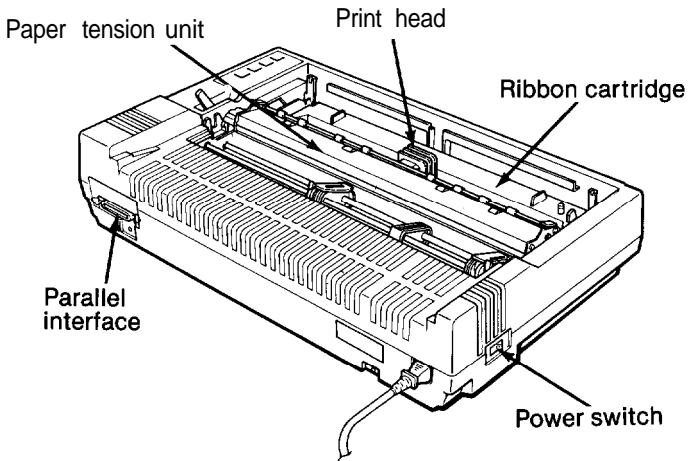
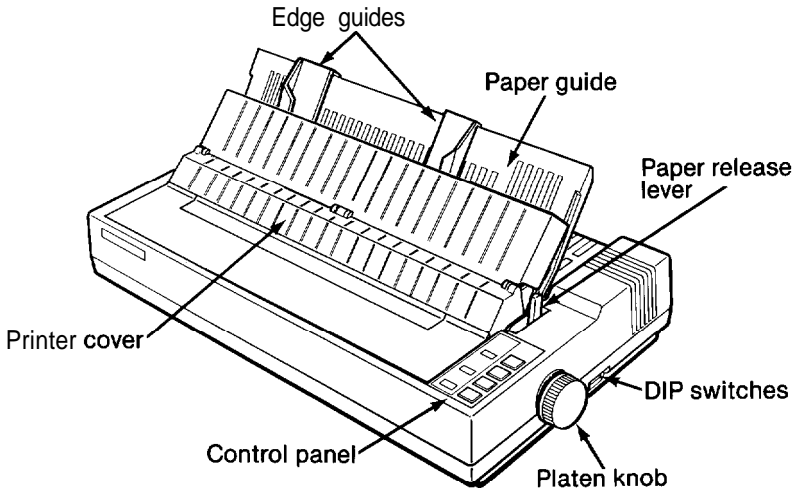

FX-850/1050

EPSON AMERICA, INC. 2780 Lomita Boulevard, Torrance, California 90505

---

**EPSON®**